

Top 100
Global
Innovator
for 10 years

Drive Solution

Low-Voltage Drive

iE5 / M100 / iG5A / G100 / S100 / H100 / iS7 / iV5

LS ELECTRIC



Contents

- 03 Introduction
- 06 LS Drive at a Glance
- 10 Guide to LS Drive Options
- 14 Micro Drive iE5
- 18 Micro Drive M100
- 20 Economical Drive iG5A
- 24 General Drive G100
- 30 Standard Drive S100
- 36 Fan & Pump Drive H100
- 40 High Performance Drive iS7
- 46 Vector Drive iV5
- 54 List of Options

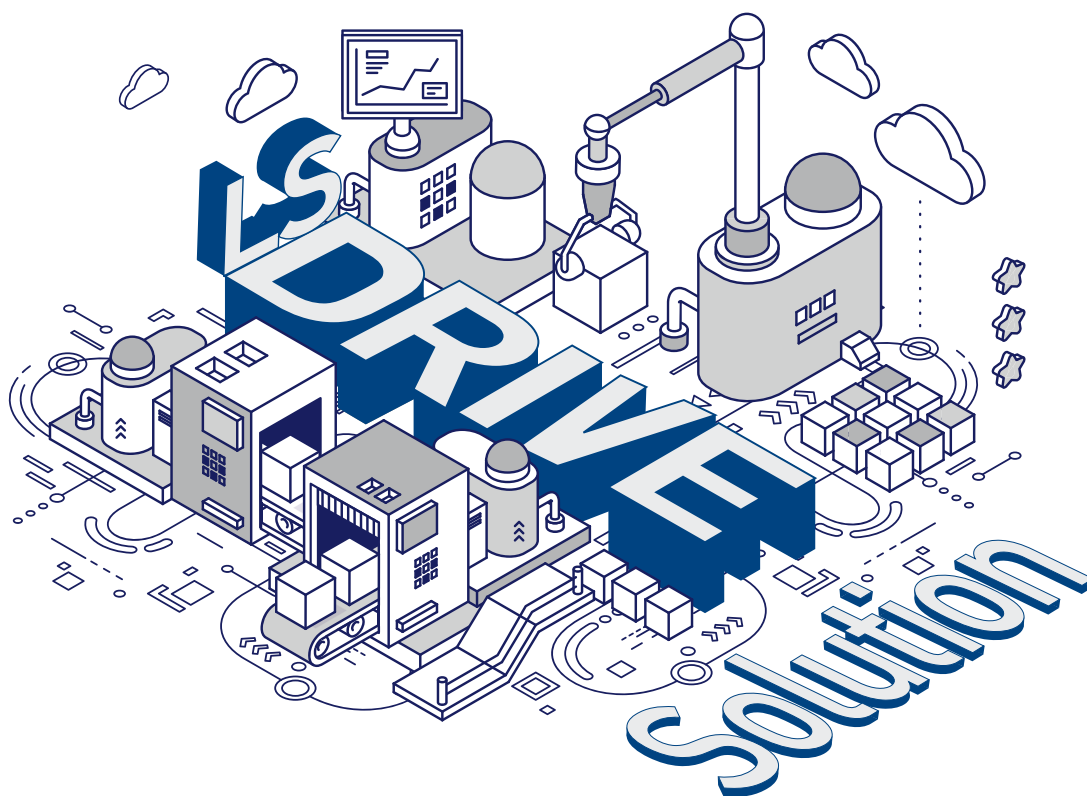



Leading Innovation, Creating Tomorrow

Realization of innovative energy saving with LS Drive Solution.

40%

Supplies 40% of the drives distributed in Korea

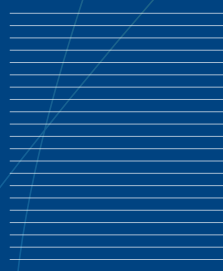

LS Drive is a control component that brings about energy saving as it controls the rotation speed of motors with changing power frequency.

LS, a leading company that first introduced a universal drive in Korea, has both obtained a lot of certificates on high-efficiency drives and produces more than 40% of the drives supplied in Korea.

LS offers an optimal solution for high efficiency and energy saving solution in various industries with the iG5A, the best-selling(3 mil.) general purpose product; the iS7, the representing LS standard line-up; the S100/H100/G100, the innovative new 100 series. Additionally, it has a medium-voltage drive that is capable of handling capacity up to 12.5MVA. It is carving out new spaces in the high value-added market such as power generation, shipbuilding, marine, cement, metal and power plant industries. With our solutions, LS was ranked top in KS-QEI (Korean Standard – Quality Excellence Index) in the area of customer satisfaction for 4 years in a row from 2013.

LS is taking a leap from the domestic leader in the drive market to a global leader and expanding the overseas market by developing differentiated products for each country and application and pursuing continuous activities for customer satisfaction.



Fulfilling the ultimate convenience with the optimal automation environment

LS provides our customers with the best solution with a configured automation environment, ranging from various unit machineries to large-scale process control.



Total Solution

LS offers a total solution instead of merely selling devices. We provide an optimal solution for our customers with our product competitiveness and delivery performance in various areas, including fans, pumps, compressors, conveyors, winding machines and extruders. With LS drives, you will meet with a new experience of increased productivity, improved product quality and reduced maintenance cost.

For Purchase to Maintenance With our Experts

You may receive specialized support from purchase to maintenance with our global LS network organization. Our experts will accompany you for purchase, installation, test (trial) run and maintenance.



LS Global Network

We have 96 special agents, 62 specialty stores, 22 authorized service depots and 4 tech-shops in Korea, offering quick and convenient services for our customers.

We have a corporation all over the world, including China, Japan, Vietnam, U.S.A, U.A.E and the Netherlands, and have 224 partners in 77 countries.

- 1 General Drive G100 **new**
- 2 Micro Drive M100 **new**
- 3 Standard Drive S100
- 4 Micro Drive iE5
- 5 Economical Drive iG5A
- 6 Fan/Pump-only Drive H100
- 7 Standard Drive S100 (NEMA4X IP66)
- 8 Fan/Pump-only Drive H100
- 9 High-Performance Standard Drive iS7
- 10 Standard Drive S100
- 11 Vector Drive iV5

LS Drive at a Glance

LS Drive is characterized by its user-convenience interface, accurate and flexible control, and various functions. LS Drive Series with varied capacities and excellent function will be an optimal option for your company's competitiveness.

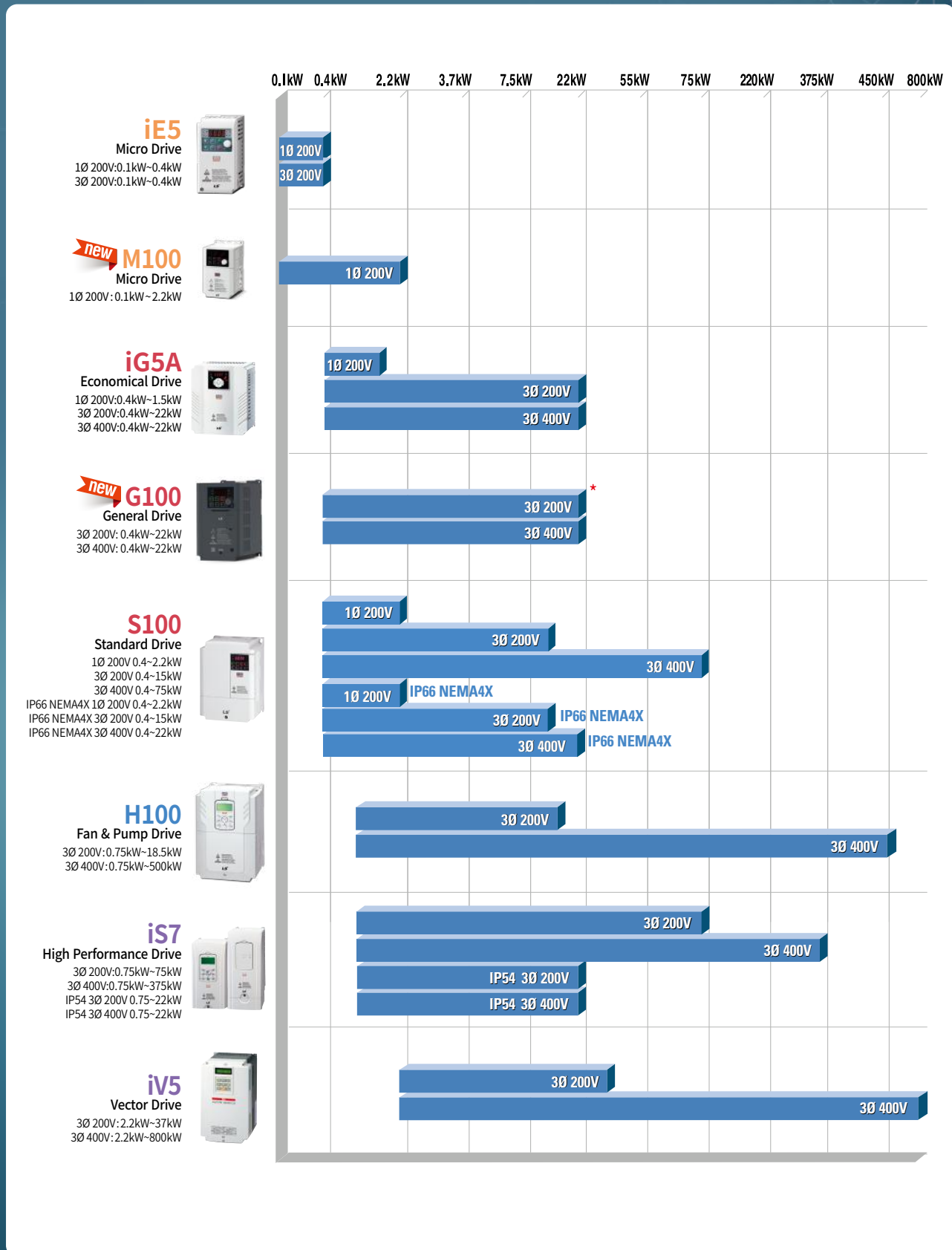

No.1 Drive in Korea! Why do you choose LS Drive?

From 1983 to the present, LS ELECTRIC has won the honor of being ranked 1st in the domestic market share, as well as 1st place in Korean quality satisfaction for 4 consecutive years*, and 9 consecutive years** in the Derwent Top 100 global innovators. LS ELECTRIC has established itself as a leading company in Korea by standing shoulder-to-shoulder with global companies with the new technology, experience and expertise gained through continuous investment in R&D.

LS Drive – Main Features



Energy Saving



Product Options



Easy to Buy



Convenient Installation & Test Run



Fast & Convenient A/S

* From 2013 to 2016, LS ELECTRIC had was selected as the No. 1 company in the Korean quality satisfaction survey hosted by the ministry of trade, industry and energy and the Korea standards association.

** From 2012 to 2020, LS ELECTRIC has was selected as the derwent Top 100 global innovators by the world's leading academic information service company, 'Clarivate analytics'.

LS Drive Comparison Table









Series Name		iE5	M100		iG5A	G100
			Standard I/O	Advanced I/O		
Voltage & Capacity		1Ø 200~230V 0.1~0.4kW 3Ø 200~230V 0.1~0.4kW	1Ø 100~120V 0.2~0.75kW 1Ø 200~240V 0.1~2.2kW		1Ø 200~230V 0.4~1.5kW 3Ø 200~230V 0.4~22kW 3Ø 380~480V 0.4~22kW	3Ø 200V 0.4~22kW [CT] 3Ø 400V 0.4~22kW [CT]
Control Mode	V/F	○	○		○	○
	Slip Compensation	-	○		○	○
	Sensorless Vector	-	○		○	○
	Sensored Vector	-	-		-	-
Overload Capacity *CT; Constant Torque *VT; Variable Torque *HD; Heavy Duty *ND; Normal Duty		Rated current 150%/1min	Rated current 150%/1min		Rated current 150%/1min	CT(HD): Rated current 150%/1min VT(ND): Rated current 120%/1min
Input Terminal	Multifunction	5 points(P1~P5)	3 points(P1~P3)	5 points(P1~P5)	8 points(P1~P8)	5 points(P1~P5)
	Analog(Voltage)	1 point(0~10V or 4~20mA)	1 point(0~10V)	1 point(0~10V)	1 point(-10~10V)	1 point(-10~10V)
	Analog(Current)		-	1 point(4~20mA)	1 point(0~20mA)	1 point(0~20mA)
	Pulse		-	-	-	-
Relay	1 point(A/B/C)		1 point(A/B/C)	2 points(A/B/C, A/C)	1 point(A/B/C)	2 points(A/B/C, A/C)
Output Terminal	Open Collector	-	1 point	-	1 point	-
	Analog	1 point(0~10V)	1 point(0~10V)	1 point(0~10V)	1 point(0~10V)	1 point(0~10V)
	Dynamic Braking Unit	-	Built-in: 1.5~2.2kW		Built-in	Built-in
EMC Filter		-	Built-in (C2)		-	Built-in: 3Ø 400V 0.4~22kW (C3)
DC Reactor		-	-		Option: 11~22kW	Option: 11~22kW
Communications (*: Under Development)	Industry Ethernet	EtherNet IP/Modbus TCP(1Port)	-	-	-	-
		EtherNet IP/Modbus TCP(2Port)	-	-	-	○
		PROFINET	-	-	-	-
		Modbus TCP(1Port)	-	-	-	-
		CC-Link IE	-	-	-	-
		RAPIDnet	-	-	-	-
	FieldBus	RAPIDnet+	-	-	-	○
		DeviceNet	-	-	-	-
		Profibus-DP	-	-	-	○
		CANopen	-	-	-	○
		CC-Link	-	-	-	-
		Modbus RTU	○(Comm. Type built-in)	○(Comm. Type built-in)	○(Built-in)	○(Built-in)
	Motion	Fnet, Rnet	-	-	-	-
		LS INV 485	-	○(Comm. Type built-in)	○(Built-in)	○(Built-in)
		EtherCAT	-	-	-	-
		BAS (Building Automation)	BACnet/IP	-	-	-
BACnet/MSTP	-		-	-	-	
Lonworks	-		-	-	-	
Other Options		-	Remote cable(1/2/3/5m), Remote keypad		Remote cable(1/2/3/5m), Remote keypad, Conduit	Remote cable(1/2/3/5m), Remote keypad, Conduit
Certification		KC, CE, UL, cUL, C-Tick	KC, CE, UL, cUL		KC, CE, UL, cUL, C-Tick	KC, CE, UL, cUL
Enclosure Type		IP20	IP20		IP20 UL type 1(Conduit option)	IP20 UL type 1(Conduit option)



S100			H100	iS7	iV5
Standard I/O	Multiple I/O	30~75kW I/O			
1Ø 200~240V 0.4~2.2kW [CT] 3Ø 200~240V 0.4~15kW [CT] 3Ø 380~480V 0.4~75kW [CT]			3Ø 200~240V 0.75~18.5kW 3Ø 380~480V 0.75~90kW 3Ø 380~500V 110~500kW	3Ø 200~230V 0.75~75kW [CT] 3Ø 380~480V 0.75~375kW [CT]	3Ø 200~230V 2.2~37kW 3Ø 380~480V 2.2~800kW DC input type 380~480V 5.5~500kW
○			○	○	-
○			○	○	-
○			-	○	○
-			-	○	○
CT(HD): Rated current 150%/1min VT(ND): Rated current 120%/1min			VT(ND) - 0.75~90kW: 120%/1min - 110~500kW: 110%/1min	CT(HD): Rated current 150%/1min VT(ND): Rated current 110%/1min	Rated current 150%/1min
5 points(P1~P5)	7 points(P1~P7)	7 points(P1~P7)	7 points(P1~P7)	8 points(P1~P8)	7 points(P1~P7), 4 points(FX,RX,BX,RST)
1 point(-10~10V)	1 point(-10~10V)	1 point(-10~10V)	1 point(-10~10V)	1 point(-10~10V)	3 points(-10V~10V, 0~20mA, NTC)
1 point(4~20mA)	1 point(4~20mA)	1 point(4~20mA)	1 point(0~20mA)	1 point(0~20mA)	
-	1 point(0~32kHz)	1 point(0~32kHz)	1 point(0~32kHz)	-	4 points(Encoder signal)
1 point(A/B/C)	1 point(A/B/C)	2 v(A/B/C, A/C)	5 points(A/B/C, A/C, A/C, A/C, A/C)	2 points(A/B/C, A/C)	3 points(A/B/C, A/C, A/C)
1 point	1 point	1 point	1 point	1 point	3 points(Encoder signal, Multifunction)
1 point(0~10V or 0~20mA)	1 point(0~10V or 0~20mA)	2 points(0~10V or 0~20mA)	2 points(0~10V or 0~20mA)	2 points(0~10V, 0~20mA)	2 points(-10V~10V)
Built-in: 0.4~22kW Option: 30~75kW			Built-in: 0.75~30kW Option: 37~500kW	Built-in: 0.75~22W Option: 30~375kW	Built-in: 2.2~22kW Option: 30~800kW
Built-In option: 1Ø 200V 0.4~2.2kW (C2) Built-In option: 3Ø 400V 0.4~4.0kW (C3) Built-in: 3Ø 400V 5.5~75kW (C3)			Built-in: 3Ø 400V 0.75~500kW (C3)	Built-in: 3Ø 200/400V 0.75~7.5kW (C2) 3Ø 200/400V 11~22kW (C3)	-
Built-in: 3Ø 400V 30~75kW			Built-in: 3Ø 400V 37~500kW	Built-in: 3Ø 200V 0.75~22kW 3Ø 400V 0.75~220kW	Option: 3Ø 200V 30/37kW 3Ø 400V 30~800kW
○			-	○	-
-			○*	○	-
○			-	○	-
-			-	-	-
-			-	○	-
-			-	○	-
-			○*	○	-
-			-	○	○
○(Excluding IP66 7.5kW or less)			-	○	○
○			-	○	-
-			-	○	○
○(Built-in)			○(Built-in)	○(Built-in)	○
-			-	○	-
○(Built-in)			○(Built-in)	○(Built-in)	○(Built-in)
○			-	-	-
-			○*	-	-
-			○(Built-in)	-	-
-			○(Built-in)	○	-
-			○(Built-in)	-	-
Extention I/O, Remote cabel(1/2/3/5m), Remote keypad, Flange, Conduit			Extention I/O, Remote cabel(2/3m), Flange, Conduit, Disconnect switch	PLC, Extention I/O, Safety(Built-In option), Synchronous, Position, Binary input, Encoder, 24V Encoder, Remote cable(2/3m)	ELIO, Sin/Cos encoder, Sin/Cos_Endat encoder, Synchronous, Extention I/O, Remote cable(2/3/5m)
KC, CE, UL, cUL, Safety			KC, CE, UL, cUL, [Marin] ABS, BV, CCS, DNV/GL, KR, LR, NK, RINA, RS	KC, CE, UL, cUL, Safety, C-Tick [Marin] ABS, BV, DNV, KR	KC, CE, UL, cUL
0.4~75kW: IP20, UL Type 1(Conduit option) 0.4~22kW: IP66(Indoor use only)			0.75~185kW: IP20 220~500kW: IP00 0.75~500kW: UL Type 1 (Conduit option)	200V Class 0.75~22kW, 400V Class 0.75~75kW : IP21 (UL Type 1(Conduit option)) 200V Class 30~75kW, 400V Class 90~375kW : IP00 (200V Class 30~75kW, IP20(Conduit option)) 0.75~22kW : IP54(UL Type 12)	IP00

Guide to LS Drive Options







The table below is to guide you in searching for products that are appropriate for your business and load among a wide range of LS drive products. For further information, please contact LS.

Application		Type				Torque		Drive Series							
		Friction Load	Gravity Load	Fluid Load	Inertia Load	CT	VT	M100	G100	S100	H100	iS7	iV5		
 HVAC Refrigerator	Fan			●			●								
	Pump			●			●								
	Compressor			●		●									
 Metals & Materials Management	Fan			●			●								
	Pump			●			●								
	Compressor			●		●									
	Conveyor	●				●									
	Press				●	●									
	Winder (Drawing Machine)				●	●									
	Winder (Stranding Machine)				●	●									
	Hoist (Hoist)		●			●									
	Hoist (Trolley, Gantry)	●				●									
	Synchronized Position Control (Grinder)	●			●	●									
	Synchronized Position Control (Automatic Lathe)	●			●	●									
 Elevator & Escalator	E/L (High Speed)		●			●									
	E/L (Low Speed)		●			●									
	Synchronized Position Control (Door Open/Close)	●				●									
	Escalator	●				●									
	Multistory Parking Space		●			●									
 Textiles	Fan			●			●								
	Pump			●			●								
	Compressor			●		●									
	Spinning Machine (Threading & Spinning)				●	●									
	Winder (Weaving)				●	●									
	Winder (Knitting)				●	●									
	Washing & Drying (Washer & Dryer)			●	●	●									
	Printing					●									
	Extruder	●				●									
	Hoist (Hoist)		●			●									
	Hoist (Trolley, Gantry)	●				●									
 Plastic & Rubber	Fan / Blower			●			●								
	Pump			●			●								
	Compressor			●		●									
	Conveyor	●				●									
	Mixer			●		●									
	Extruder	●				●									
	Screw & Vibration Feeder				●	●									
	Injection Molding	●				●									
	Winder				●	●									
	Hoist (Hoist)		●			●									
	Hoist (Gantry, Trolley)					●									
 Energy	Fan			●			●								
	Pump			●			●								
	Compressor			●		●									
	Conveyor	●				●									
	Hoist (Hoist)		●			●									
	Hoist (Gantry, Trolley)					●									
	High-capacity Fan & Pump (Power Generation Industry)			●			●								

Optimal Suitable

Description	Reason(s) for Choosing the Product
<p>It refers to a HVAC system related to heating, ventilation and air-conditioning, and its primary purpose is to control the building or factory's temperature and humidity.</p> <p>A refrigerator requires diverse analogue inputs and contact outputs for constant temperature control.</p>	<ul style="list-style-type: none"> ● H100 <p>As a drive exclusive for HVAC, it has exclusive functions applied to Fan/ Pump, including a reservation function, advanced PID, Master/Follower and so forth.</p> <p>iS7 extended IO may be used for multifunction and analogue I/O extension.</p>
<p>Metals are composed of ID/FD Fan/Pump for cooling from the stages of transferring raw materials (conveyor or hoist), casting and winding.</p>	<ul style="list-style-type: none"> ● iS7 / iV5 / iG5A / iC5 <p>Unlike other load types, the load of metals is larger, heavier and greater in tension. Thus, products that are equipped with sensor-less and sensed vector control as well as helper roll and winding control are needed.</p> <p>Hoist is used for load transfer also needs products that are easier to ensure torque.</p>
<p>It is a power device used to transport persons or cargo, which consists of a (ultra) high-speed unit for passengers, (medium) low-speed unit for passengers, a unit for view; for hospital; for cargo; for vehicles and dumbwaiter.</p> <p>It requires a high noise level.</p>	<ul style="list-style-type: none"> ● iV5 / iV5L / iS7 <p>Sensor-less and sensed vector mode for powerful torque control and E/L-only S/W are provided as a default.</p> <p>In case of iV5, optimal drive is realized with an exclusive position control-based function.</p>
<p>There are a wide range of processes, including threading, drawing, yarn dyeing, warping, beaming, weaving (loom), inspecting gray goods, refining, reducing, washing, dyeing and stenter process, so various loads ranging from the low-end load to high-end load of winders and twisters exist.</p> <p>Corrosion resistance and waterproof are required as there are a lot of high temperature and humidity environments.</p>	<ul style="list-style-type: none"> ● For VT load: iP5A / H100 ● For CT load: iS7 / iV5 / iV5L ● For low-capacity load: S100 / iG5A <p>Products that meet various process features may be chosen.</p> <p>In particular, iS7, S100 built-in with S/W exclusive for winders uses WEB PID for precise winding. All products are applied with PCB Conformal Coating.</p>
<p>There are processes such as injection molding to create a model by melting raw materials or winding the produced artificial thread and printed films.</p> <p>A part of injection molding is mixed with servo system for use, and it requires an accurate position control or torque control.</p>	<ul style="list-style-type: none"> ● iS7 / S100 / iG5A <p>iS7 installed with S/W exclusive for winders along with synchronization and position control is one of the representative products. S100 built-in with S/W only for winders is also used.</p> <p>It is recommended to use iG5A or equivalent for small-capacity helper roll and conveyor.</p>
<p>HVAC load is the major part of Energy, and the load of ID/FD Fan/Pump applied for power generation industry and the load that goes along with the high efficiency system in the local environment are the main components.</p>	<ul style="list-style-type: none"> ● iP5A / H100 / iS7 <p>We recommend inverter products that have obtained a certificate of high efficiency.</p> <p>iS7 may be used to partially respond to CT load.</p> <p>Without a separate controller, a built-in PID is capable of controlling pressure and flow.</p>

Guide to LS Drive Options

Application	Type				Torque		Drive Series					
	Friction Load	Gravity Load	Fluid Load	Inertia Load	CT	VT	M100	G100	S100	H100	iS7	iV5
 Marin	Fan		●			●						
	Pump		●			●						
	Compressor			●		●						
	Conveyor	●				●						
	Winch (Hoist)		●			●						
	Winch (Gantry, Trolley)	●				●						
	Hoist (Hoist)		●			●						
	Hoist (Gantry, Trolley)					●						
 Food & Beverage	Fan		●			●						
	Pump		●			●						
	Compressor			●		●						
	Conveyor	●				●						
	Mixer			●		●						
	Extruder	●				●						
	Packing Machine (Synchronization, Position Control)	●				●						
	Cutting Machine (Synchronization, Position Control)	●				●						
	Labeling Machine (Synchronization, Position Control)	●				●						
	Hoist (Hoist)		●			●						
	Hoist (Gantry, Trolley)					●						
	 Pulp & Paper	Fan		●			●					
Agitator Pump				●		●						
Compressor				●		●						
Winder (Fixed Contact Control)					●	●						
Roller Drum					●	●						
Drying Machine		●				●						
Coating Machine		●				●						
Slitter		●				●						
Hoist (Hoist)			●			●						
Hoist (Gantry, Trolley)						●						
 Mining		Fan		●			●					
	Pump			●		●						
	Compressor			●		●						
	Conveyor	●				●						
	Crusher / Drill Machine	●				●						
	Excavators					●						
	Crane (Hoist)		●			●						
	Crane (Gantry/Trolley, Rotating/Turning)	●				●						
	Hoist (Hoist)		●			●						
	Hoist (Gantry, Trolley)					●						
 Oil & Gas Chemical	Fan (Blower)		●			●						
	Oil & Rod Pump			●		●						
	Compressor			●		●						
	Conveyor	●				●						
	Mixer			●		●						
	Extruder					●						
 Crane & Hoist	Crane (Hoist)		●			●						
	Crane (Gantry/Trolley, Rotating/Turning)	●				●						
	Hoist (Hoist)		●			●						
	Hoist (Gantry, Trolley)					●						
	Automatic Warehouse (Lift)		●			●						
	Automatic Garage (Gantry)	●				●						
 Water & Wastewater	Fan		●			●						
	Pump			●		●						
	Compressor			●		●						
	Mixer			●		●						

Optimal Suitable

Description	Reason(s) for Choosing the Product
<p>When the distributed control system was introduced in 1990s, automated processes were realized in various systems, including automatic and power control of generators; ballast and pump motors for cargo; and valve control. As IMO environmental regulation came into effect, the needs for auto control and energy efficiency have been accelerated.</p> <p>The classification system such as ABS (USA) /BV (France) /DNV (Norway) /LR (USA) /RINA (Italy) is required.</p>	<ul style="list-style-type: none"> ● iS7 / iP5A <p>These products that have obtained the certificate of classification are included in a lineup, which are gradually applied in the shipping industry.</p> <p>Based on the classification, the products have satisfied the power and environmental requirements necessary for ship installation. Also, there are reference cases of applying the products for merchant ships and marine cranes.</p>
<p>High-performance IP products with a high-pressure jet function for washing are required for food sanitation and contamination prevention.</p> <p>Furthermore, customers prefer Decentralized Drives and there is growing demand for drives with functions such as accurate positioning and synchronizing of packing machines, labeling machines and conveyors.</p>	<ul style="list-style-type: none"> ● iS7(IP54) / S100(IP66) <p>General load is applicable to ensure water and dust resistance.</p>
<p>In general, it is a load with smaller tension when compared with steel so precise control and fast responsiveness are needed. In most cases, it is fabricated as a System Drive (AFE + DC-type inverter).</p> <p>Wood or raw materials that have completed primary operation are chemically treated to produce paper, artificial fiber and etc.</p>	<ul style="list-style-type: none"> ● iS7 / iV5(DC Input Type) <p>DC input-type inverter products or any product with a DC input function may be applied.</p>
<p>Anti-environment properties such as explosion, dust and water resistance are needed, and higher reliability with application of a long-distance line is required.</p> <p>In case of excavators operated underground, the drive with higher performance and reliability to respond to high-torque, heavy duty load is required.</p>	<ul style="list-style-type: none"> ● iS7 <p>The product was applied to cases such as subway construction, submarine tunnel and underground line construction, and high-powered devices with torque-synchronized operation are applicable.</p> <p>With our experiences in drive application to various power and user environmental settings, air-conditioning, pump and hoist units are applicable.</p>
<p>High-capacity power and long-distance line application are needed when applied to large plants. The product should be highly reliable when it comes to risk including fire accidents as large-capacity products are applied for air-conditioning, pump and production.</p>	<ul style="list-style-type: none"> ● iS7 / H100 <p>We have reference cases in the field of petrochemical and oil refining industry, and we offer various options and large-capacity products with the Drive System-applied technologies.</p>
<p>3 basic operation modes include Hoist, Gantry and Trolley, and there is an additional function, Boom up/down, for marine cranes.</p> <p>Although features required for inverters differ according to the operation mode, they generally transport heavy cargo. Thus, it is recommended to use sensor-less and sensed vector mode.</p>	<ul style="list-style-type: none"> ● iS7 / iV5 / S100 <p>We recommend a lineup of products with sensor-less and sensed vector control functions that make it easier to ensure torque as heavy load is expected.</p>
<p>Harmful gases generated upon sewage treatment should be prevented (coating), and it is HVAC App that generally requires a low level of THD. (AFE, Low Harmonic Drive)</p>	<ul style="list-style-type: none"> ● iP5A / H100 <p>A lineup of inverter products exclusively for HVAC system can be applied to all water treatment industry.</p>

iE5

Micro Drive



- 1Ø 200V Class 0.1~0.4kW
- 3Ø 200V Class 0.1~0.4kW



iE5, Compact Size With Powerful Performance

It is our smallest drive that offers an optimal solution for controlling small-capacity motors.

Although compact in size, it demonstrates powerful performance with various functions.



Mini Drive Maximizing Space Efficiency

The drive's compact size (68mm × 128mm × 85mm(W×H×D)) has increased its space efficiency.



Easy Operation Method

6 keys in total are used for operation and volume resistance method is applied. Less than 100 parameters are available, which improves operational convenience.



Intended Use

- Treadmill
- Vibratory motion machine
- Packaging machine
- Small conveyor

Product Type & Model

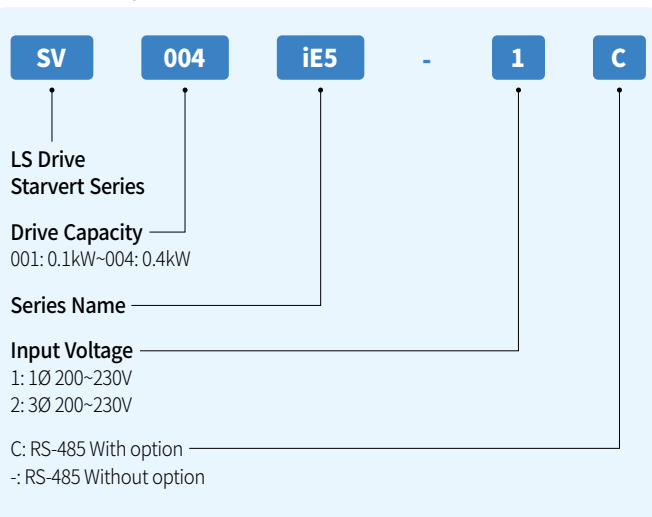

Main Functions

Features	Description	Benefits
Micro Size	Micro drive's size: 68mm x 85mm x 128mm (W x D x H)	Maximized installation convenience and space efficiency
Easy and Convenient Operation	With 6 keys based on volume resistance, less than 100 parameters are quickly operable	Easy and fast operation with various functions suitable for small machinery operation
Communication Interface	Modbus communication support (Option)	Remote controlling with PLC and other controllers
Global Standard Requirement	Obtained CE, UL and ROHS certification	Reliability guaranteed and eco-friendly drive

Control

Control Mode	V/F
Frequency Setting Resolution	Digital command: 0.01Hz; analogue command: 0.06Hz (peak frequency: 60Hz)
Frequency Setting Level	Digital command operation: 0.01% of the peak output frequency; Analogue command operation: 0.1% of the peak output frequency
V/F Pattern	Linear, square-law torque reduction, user V/F
Overload Capacity	150% 1min
Torque Boost	Passive torque boost, auto torque boost

Operation

Operation Mode	Operation mode is optional among Loader / Terminal Block / Communication Network	
Frequency Setting	Analogue method: 0~10 (V), 0~20 (mA), loader volume, digital method: loader	
Operation Function	PID control, up-down operation, 3-wire operation	
Input	Multifunctional Terminal (5points) P1, P2, P3, P4, P5	NPN / PNP optional Function: Forward operation; backward operation; emergency trip; reset upon trouble; jog operation; switching frequency -DC brake through up, down and stop; frequency increase; frequency decline; 3-wire operation; external trip A, B; switching to general operation from PI operation; analogue command fixed frequency; acceleration/deceleration stop option; delete saved frequency with Up/Down
	Multifunctional Relay Terminal	Fault output and drive operation mode output (N.O., N.C.) AC250V 0.3A or below, DC30V 1A or below
	Analogue Output	0 ~ 10 Vdc (10mA or below): Selectable among frequency, current, voltage and DC voltage

1Ø/3Ø 200V Class

SV□□□iE5□		001-1	002-1	004-1	001-2	002-2	004-2	
Applied Motor ^{Note 1)}	Heavy Duty	(HP)	1/8	1/4	1/2	1/8	1/4	1/2
		(kW)	0.1	0.2	0.4	0.1	0.2	0.4
Output	Rated Capacity (kVA) ^{Note 2)}		0.3	0.6	0.95	0.3	0.6	1.14
	Rated Current (A)		0.8	1.4	2.5	0.8	1.6	3.0
	Rated Frequency (Hz)		0~200 (Hz)					
	Rated Voltage (V)		3Ø 200~230V ^{Note 3)}					
Input	Rated Voltage (V)		1Ø 200~240VAC (-15% ~ +10%)			3Ø 200~230VAC (±10%)		
	Rated Frequency (Hz)		50~60Hz (±5%)					
	Rated Current (A)		2.0	3.5	5.5	1.2	2.0	3.5
Weight (kg)		0.44	0.46	0.68	0.43	0.45	0.67	

Note 1) The maximum applicable capacity of 4-pole OTIS standard motor is marked for the Applied Motor.

Note 2) The rated capacity is based on 220V.

Note 3) The maximum power voltage does not exceed the source voltage. The output voltage can be set within the source (power supply) voltage.

Product Dimension

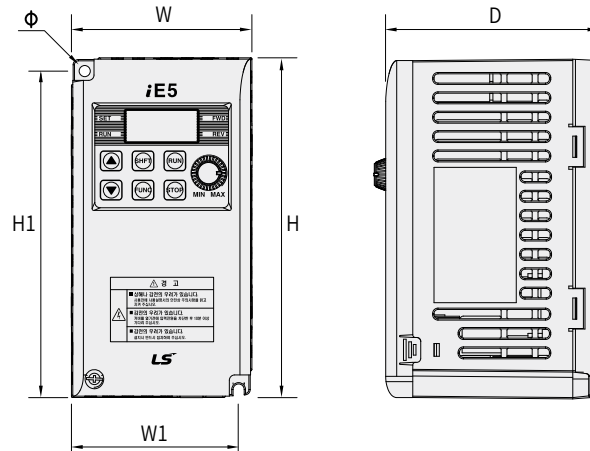

Unit: mm (inches)

Model	W	H	D	H1	W1	Ø
SV0001iE5-1	68 (2.67)	128 (5.03)	85 (3.34)	124 (4.88)	64 (2.51)	4.2 (0.16)
SV0002iE5-1	68 (2.67)	128 (5.03)	85 (3.34)	124 (4.88)	64 (2.51)	4.2 (0.16)
SV0004iE5-1	68 (2.67)	128 (5.03)	115 (4.52)	124 (4.88)	64 (2.51)	4.2 (0.16)
SV0001iE5-2	68 (2.67)	128 (5.03)	85 (3.34)	124 (4.88)	64 (2.51)	4.2 (0.16)
SV0002iE5-2	68 (2.67)	128 (5.03)	85 (3.34)	124 (4.88)	64 (2.51)	4.2 (0.16)
SV0004iE5-2	68 (2.67)	128 (5.03)	115 (4.52)	124 (4.88)	64 (2.51)	4.2 (0.16)

Note) Use M4 screws to fix the product to panels.



Memo

Energy Saving Drive

Large empty rectangular area for writing the memo content.



M100

Micro Drive

new



- 1Ø 115V : 0.2~0.75kW
- 1Ø 200V Class 0.1~2.2kW

An Optimal Compact Drive That is Applicable to Small Unit Machinery, Fans/Pumps and Conveyors.

Space efficiency is increased with a compact product design, side-by-side installation and standard installation of Din Rail. Product reliability is improved with a built-in C2 EMC filter and application of a new UL standard. We offer two I/O types (standard type and advanced type), frequently-used parameter group, built-in potentiometer and parameter copier/remote keypad options. We ensure that users may easily install and use products.



Compact

M100 Drive is a small device that is cost-effective. Space efficiency has increased with side-by-side installation.



Convenient Use

Din Rail installation is standard for M100 Drive, and RJ45 Port is provided for an easier connection with peripheral devices.



Intended Use

- Refrigerant compressor, air conditioner, refrigerator
- IAQ (Indoor Air Quality) industry sector
- Cargo terminal transfer line (Conveyor)
- Packaging machine transfer line (Conveyor)
- Unit machinery such as a lens grinder, spinning wheel and etc.



Product Type & Model

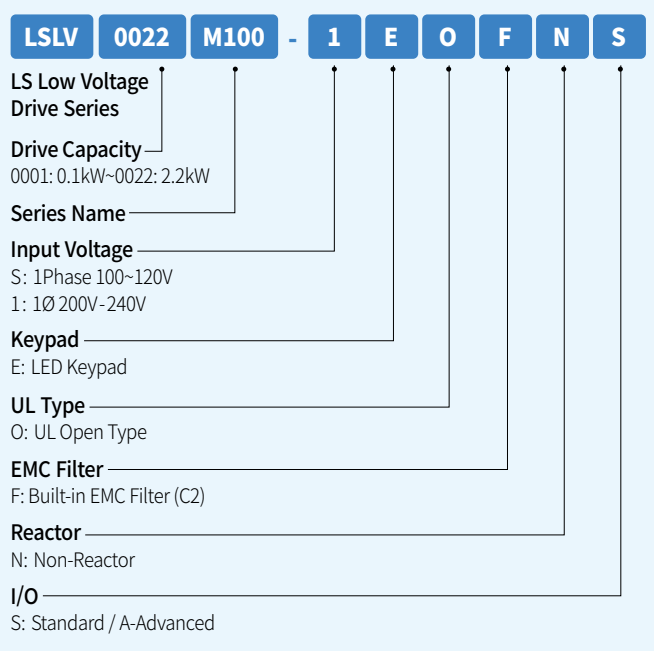

Main Functions

Features	Description	Benefits
Micro Size	85×135×100mm (W x H x D); Mini drive (based on 0.2kW)	Reduced area for product installation and increased convenience
EMC Filter	Filter that satisfies the following standard: EN61800-3 Category C2 (1st Environment)	No space and expenses for additional filter to reduce electromagnetic noise are needed
DIN Rail Installation	DIN rail and wall fixation to the rear and sides of the product with removal clips	Fast and easy product installation that lasts less than 5 minutes and maximized space efficiency through side-by-side installation
Quick Parameter Menu	Frequently-used useful parameters can be listed in the Quick Parameter group	Quick setting and improved operational convenience according to the customer's application type
Potentiometer	Standard potentiometer for analogue setting	Easy and flexible operation setting
Global Standard Requirement	Obtained CE certification and new UL 61800-5-1 standard	Ensures product reliability (Improved quality of insulation distance)

Control

Control Mode	V/F, Slip compensation, Simple sensorless
Frequency Setting Resolution	Digital command: 0.01Hz Analog command: 0.06Hz/60Hz
Frequency Setting level	1% of Max. Output frequency
V/F Pattern	Linear, Square-law torque reduction, user V/F
Overload Capacity	Rated current: 150% 1min
Torque Boost	Passive torque boost, Auto torque boost

Operation

Operation Mode	Keypad/Terminal/Communication	
Frequency Setting	Analog: V1 0~10[V], I2(Advanced I/O) 0~20[mA] Digital: Keypad	
Operation Function	<ul style="list-style-type: none"> • Forward/Reverse rotation prevention • Frequency jump • Frequency limit • DC brake • Jog operation • up-down operation • 3-wire operation 	<ul style="list-style-type: none"> • Dwell operation • Slip compensation • PID control • Energy saving operation • Speed search • Auto restart

1Ø 100~200V Class

Division			1 Phase 100~120V			1 Phase 200~240V					
			0002	0004	0008	0001	0002	0004	0008	0015	0022
Applied Motor	Heavy Duty	(HP)	0.25	0.5	1.0	0.125	0.25	0.5	1.0	2.0	3.0
		(kW)	0.2	0.4	0.75	0.1	0.2	0.4	0.75	1.5	2.2
Rated Output	Rated Capacity (kVA)		0.6	0.95	1.9	0.3	0.6	0.95	1.9	3.0	4.5
	Rated Current (A)		1.4	2.4	4.2	0.8	1.4	2.4	4.2	7.5	10.0
	Frequency (Hz)		0~400Hz			0~400Hz					
Voltage (V)			1Ø 200~240V			1Ø 100~120V					
Rated Input	Rated Current (A)		3.7	7.4	13.9	1.0	1.8	3.7	7.1	13.6	18.7
	Frequency (Hz)		50~60Hz (±5%)			50~60Hz (±5%)					
	Voltage (V)		1Ø 100-120Vac (-15% to +10%)			1 phase 200-240Vac (-15% to +10%)					
Cooling Type			Natural cooling			Natural cooling		Forced fan cooling			
Weight (kg)			1		1.36	0.66		1		1.45	

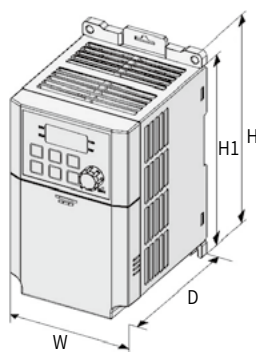

Product Dimension

Unit: mm (inches)

1 Phase 100~120V	W	H1	H	D	1 Phase 200~240V	W	H1	H	D
0002M100-S	85	163	153	123	0001M100-1 0002M100-1	85	145	135	100
0004M100-S	(3.34)	(6.42)	(6.02)	(4.84)			(5.70)	(5.31)	(3.93)
0008M100-S	100	190	180	140	0004M100-1 0008M100-1	(3.34)	163	153	123
					(6.42)		(6.02)	(4.84)	
0008M100-S	(3.94)	(7.48)	(7.08)	(5.51)	0015M100-1 0022M100-1	(3.94)	190	180	140
					(7.48)		(7.08)	(5.51)	

iG5A

Economical Drive



- 1Ø 200V Class 0.4~1.5kW
- 3Ø 200V Class 0.4~22kW
- 3Ø 400V Class 0.4~22kW

iG5A, a Compact-sized, Powerful drive

It is one of the representative LS drives, which is compact in size with high-powered sensor-less vector.



Excellent Torque Performance at Low Speed With Sensor-less Vector Control

It shows powerful torque performance with outstanding motor control capability through sensor-less vector control.



User-centered Operation and Maintenance Convenience

It is a cutting-edge drive with a useful 4-way key for easier parameter setting. Maintenance is taken into consideration with a self-diagnosis function and cooling fan On/Off function.



Intended Use

Applied to the following industries: metal, elevator/escalator, textile machinery, plastic/rubber, energy, shipping, food and beverage, pulp/paper, coal mine and water treatment

- Hoist (hoist, trolley, gantry)
- Fan/Pump
- Compressor
- General crane
- Conveyor

Product Type & Model

SV 004 iG5A - 2

LS Drive
Starvert Series

Drive Capacity
004: 0.4kW~022: 2.2kW

Series Name

Input Voltage
1: 1Ø 200~230V
2: 3Ø 200~230V
4: 3Ø 380~480V



Main Functions

Features	Description	Benefits
Built-in DB Circuit	Braking resistor can be accessed with a built-in DB circuit	Slowing down time can be shortened easily at the load with high regenerative power; improved productivity and controllability
Various Programming Function	Sensor-less vector control, improved PID function, Sleep & Wake up function and etc.	Although small in size, the drive demonstrates high power and functions
Protective Function	Ground protection upon operation, leakage reduction PWM algorithm and KEB B	Operable under highly humid environmental setting; automatic load cutoff upon power failure to protect the customer's equipment
Externally Installed Loader (Loader)	Optional loader for installation outside the panel	Drive monitoring and control outside the panel; same parameters can be copied to several drives
Cooling Fan Control	Cooling fan operation On/Off control and easily replaceable without removing the drive cover	Increased fan life by controlling the cooling fan according to the internal temperature and easier maintenance

Control

Control Mode	V/F, sensor-less vector control
Frequency Setting Resolution	Digital command: 0.01Hz; analogue command: 0.06Hz/60Hz
Frequency Setting level	Digital: 0.01% of the peak output frequency Analogue: 0.1% of the peak output frequency
V/F Pattern	Linear, square-law torque reduction, user V/F
Overload Capacity	150% 1min
Torque Boost	Passive torque boost (0 ~ 15% setting); auto torque boost
Regenerative Braking Torque	Maximum Braking Time/Usage
	20% ^{Note1)} 150%, when using a separately-installed braking resistor ^{Note2)}

Note 1) Regenerative braking torque 20% refers to the mean braking torque resulting from motor loss upon decelerated pause.

Note 2) Please refer to our Manual for further details on rating of the braking resistor.

Operation

Operation Mode	Loader / Terminal Block / Communication Network / Remote Loader options	
Frequency Setting	Analogue method: 0 ~ 10 (V), -10 ~ 10 (V), 0 ~ 20 (mA); digital method: loader	
Operation Function	PID control, up-down operation, 3-wire operation	
Input	Multifunctional Terminal (8points) P1~P8	NPN / PNP option
		Function: Forward operation; backward operation; emergency trip; reset upon trouble; jog operation; switching frequency – high / middle / low; acceleration and deceleration by stage – high / middle / low; DC braking upon pause; second motor option; up-down operation (frequency increase/decline; 3-wire operation; external trip signal input (A/B contact); self-diagnosis; switching to general operation during PID operation; 2nd Source; analogue command fixed frequency; acceleration and deceleration stop; up-down frequency save option; jog forward/backward operation
Output	Multifunctional, Open Collector Terminal	Fault output and drive operation mode output
	Multifunctional Relay Terminal	DC 24V 50mA or below (N.O.,N.C.) AC 250V 0.3A or below, DC 30V 1A or below
	Analogue Output	0 ~ 10 Vdc (10mA or below): Selectable among output frequency, output current, output voltage and drive DC voltage

1Ø 200V Class

SV□□□ iG5A-1□		004	008	015	
Applied Motor <small>Note 1)</small>	Heavy Duty	(HP)	0.5	1	2
		(kW)	0.4	0.75	1.5
Output	Rated Capacity (kVA) <small>Note 2)</small>		0.95	1.9	3.0
	Rated Current (A) <small>Note 3)</small>		2.5	5	8
	Rated Frequency (Hz)		400 (Hz) <small>Note 4)</small>		
	Rated Voltage (V)		3Ø 200~230V <small>Note 5)</small>		
Input	Rated Voltage (V)		1Ø 200~230 VAC (+10%, -15%)		
	Rated Frequency (Hz)		50~60 (Hz) (±5%)		
Cooling Method		Forced air cooling			
Weight (kg)		0.77	1.12	1.84	

3Ø 200V Class

SV□□□ iG5A-2□		004	008	015	022	037	040	055	075	110	150	185	220	
Applied Motor <small>Note 1)</small>	Heavy Duty	(HP)	0.5	1	2	3	5	5.4	7.5	10	15	20	25	30
		(kW)	0.4	0.75	1.5	2.2	3.7	4.0	5.5	7.5	11	15	18.5	22
Output	Rated Capacity (kVA) <small>Note 2)</small>		0.95	1.9	3.0	4.5	6.1	6.5	9.1	12.2	17.5	22.9	28.2	33.5
	Rated Current (A) <small>Note 3)</small>		2.5	5	8	12	16	17	24	32	46	60	74	88
	Rated Frequency (Hz)		400 (Hz) <small>Note 4)</small>											
	Rated Voltage (V)		3Ø 200~230V <small>Note 5)</small>											
Input	Rated Voltage (V)		3Ø 200~230 VAC (+10%, -15%)											
	Rated Frequency (Hz)		50~60 (Hz) (±5%)											
Cooling Method		Natural cooling	Forced air cooling											
Weight (kg)		0.76	0.77	1.12	1.84	1.89	1.89	3.66	3.66	9.00	9.00	13.3	13.3	

3Ø 400V Class

SV□□□ iG5A-4□		004	008	015	022	037	040	055	075	110	150	185	220	
Applied Motor <small>Note 1)</small>	Heavy Duty	(HP)	0.5	1	2	3	5	5.4	7.5	10	15	20	25	30
		(kW)	0.4	0.75	1.5	2.2	3.7	4.0	5.5	7.5	11	15	18.5	22
Output	Rated Capacity (kVA) <small>Note 2)</small>		0.95	1.9	3.0	4.5	6.1	6.9	9.1	12.2	18.3	22.9	29.7	34.3
	Rated Current (A) <small>Note 3)</small>		1.25	2.5	4	6	8	9	12	16	24	30	39	45
	Rated Frequency (Hz)		400 (Hz) <small>Note 4)</small>											
	Rated Voltage (V)		3Ø 380~480V <small>Note 5)</small>											
Input	Rated Voltage (V)		3Ø 380~480 VAC (+10%, -15%)											
	Rated Frequency (Hz)		50~60 (Hz) (±5%)											
Cooling Method		Forced air cooling												
Weight (kg)		0.76	0.77	1.12	1.84	1.89	1.89	3.66	3.66	9.00	9.00	13.3	13.3	

Note 1) The maximum applicable capacity of 4-pole OTIS-LG standard motor is marked for the Applied Motor.

Note 2) For the rated capacity, the input capacity of 200V class is based on 220V and that of 400V class is based on 440V.

Note 3) Please refer to our Manual when the carrier frequency (H39) setting is 3kHz or above. (Page 13-4)

Note 4) When No.3 (sensor-less vector control) is chosen for H40 (control mode option), the peak frequency can be set up to 300Hz.

Note 5) The peak output voltage does not exceed the source voltage. The output voltage can be set within the source (power supply) voltage.

Product Dimension

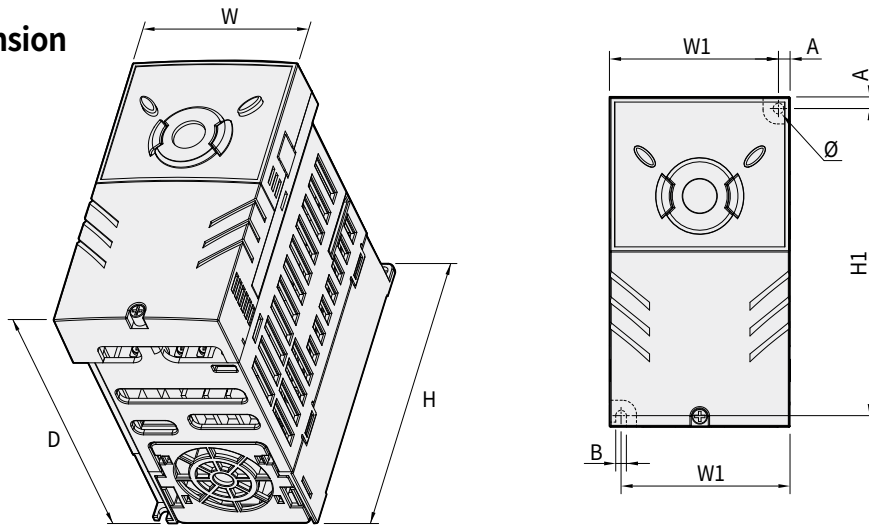

Unit: mm (inches)

Model	kW	W	W1	H	H1	D	A	B	Ø
SV004iG5A-1	0.4	70 (2.85)	65.5 (2.57)	128 (5.03)	119 (4.68)	130 (5.11)	4.5 (0.17)	4.0 (0.15)	4.0 (0.15)
SV004iG5A-2	0.4	70 (2.85)	65.5 (2.57)	128 (5.03)	119 (4.68)	130 (5.11)	4.5 (0.17)	4.0 (0.15)	4.0 (0.15)
SV008iG5A-2	0.75	70 (2.85)	65.5 (2.57)	128 (5.03)	119 (4.68)	130 (5.11)	4.5 (0.17)	4.0 (0.15)	4.0 (0.15)
SV004iG5A-4	0.4	70 (2.85)	65.5 (2.57)	128 (5.03)	119 (4.68)	130 (5.11)	4.5 (0.17)	4.0 (0.15)	4.0 (0.15)
SV008iG5A-4	0.75	70 (2.85)	65.5 (2.57)	128 (5.03)	119 (4.68)	130 (5.11)	4.5 (0.17)	4.0 (0.15)	4.0 (0.15)
SV008iG5A-1	0.75	100 (3.93)	95.5 (3.75)	128 (5.03)	120 (4.72)	130 (5.11)	4.5 (0.17)	4.5 (0.17)	4.5 (0.17)
SV015iG5A-2	1.5	100 (3.93)	95.5 (2.57)	128 (5.03)	120 (4.72)	130 (5.11)	4.5 (0.17)	4.5 (0.17)	4.5 (0.17)
SV015iG5A-4	1.5	100 (3.93)	95.5 (2.57)	128 (5.03)	120 (4.72)	130 (5.11)	4.5 (0.17)	4.5 (0.17)	4.5 (0.17)
SV015iG5A-1	1.5	140 (5.51)	132 (5.19)	128 (5.03)	120.5 (4.74)	155 (6.10)	4.5 (0.17)	4.5 (0.17)	4.5 (0.17)
SV022iG5A-2	2.2	140 (5.51)	132 (5.19)	128 (5.03)	120.5 (4.74)	155 (6.10)	4.5 (0.17)	4.5 (0.17)	4.5 (0.17)
SV037iG5A-2	3.7	140 (5.51)	132 (5.19)	128 (5.03)	120.5 (4.74)	155 (6.10)	4.5 (0.17)	4.5 (0.17)	4.5 (0.17)
SV040iG5A-2	4.0	140 (5.51)	132 (5.19)	128 (5.03)	120.5 (4.74)	155 (6.10)	4.5 (0.17)	4.5 (0.17)	4.5 (0.17)
SV022iG5A-4	2.2	140 (5.51)	132 (5.19)	128 (5.03)	120.5 (4.74)	155 (6.10)	4.5 (0.17)	4.5 (0.17)	4.5 (0.17)
SV037iG5A-4	3.7	140 (5.51)	132 (5.19)	128 (5.03)	120.5 (4.74)	155 (6.10)	4.5 (0.17)	4.5 (0.17)	4.5 (0.17)
SV040iG5A-4	4.0	140 (5.51)	132 (5.19)	128 (5.03)	120.5 (4.74)	155 (6.10)	4.5 (0.17)	4.5 (0.17)	4.5 (0.17)
SV055iG5A-2	5.5	180 (7.08)	170 (6.69)	220 (8.66)	210 (8.26)	170 (6.69)	5 (0.19)	4.5 (0.17)	4.5 (0.17)
SV075iG5A-2	7.5	180 (7.08)	170 (6.69)	220 (8.66)	210 (8.26)	170 (6.69)	5 (0.19)	4.5 (0.17)	4.5 (0.17)
SV055iG5A-4	5.5	180 (7.08)	170 (6.69)	220 (8.66)	210 (8.26)	170 (6.69)	5 (0.19)	4.5 (0.17)	4.5 (0.17)
SV075iG5A-4	7.5	180 (7.08)	170 (6.69)	220 (8.66)	210 (8.26)	170 (6.69)	5 (0.19)	4.5 (0.17)	4.5 (0.17)
SV110iG5A-2	11.0	235 (9.25)	219 (8.62)	320 (12.59)	304 (11.96)	189.5 (7.46)	8.0 (0.31)	7.0 (0.31)	7.0 (0.31)
SV150iG5A-2	15.0	235 (9.25)	219 (8.62)	320 (12.59)	304 (11.96)	189.5 (7.46)	8.0 (0.31)	7.0 (0.31)	7.0 (0.31)
SV110iG5A-4	11.0	235 (9.25)	219 (8.62)	320 (12.59)	304 (11.96)	189.5 (7.46)	8.0 (0.31)	7.0 (0.31)	7.0 (0.31)
SV150iG5A-4	15.0	235 (9.25)	219 (8.62)	320 (12.59)	304 (11.96)	189.5 (7.46)	8.0 (0.31)	7.0 (0.31)	7.0 (0.31)
SV185iG5A-2	18.5	260 (10.23)	240 (9.44)	410 (16.14)	392 (15.43)	208.5 (8.20)	10.0 (0.39)	10.0 (0.39)	10.0 (0.39)
SV220iG5A-2	22.0	260 (10.23)	240 (9.44)	410 (16.14)	392 (15.43)	208.5 (8.20)	10.0 (0.39)	10.0 (0.39)	10.0 (0.39)
SV185iG5A-4	18.5	260 (10.23)	240 (9.44)	410 (16.14)	392 (15.43)	208.5 (8.20)	10.0 (0.39)	10.0 (0.39)	10.0 (0.39)
SV220iG5A-4	22.0	260 (10.23)	240 (9.44)	410 (16.14)	392 (15.43)	208.5 (8.20)	10.0 (0.39)	10.0 (0.39)	10.0 (0.39)

G100

General Drive

new



- 3Ø 200V Class 0.4kW~22kW
- 3Ø 400V Class 0.4kW~22kW



Scan the QR code marked on the product cover for further details on this product.



GOOD DESIGN



G100, an Optimal General Drive for Various Industrial Sectors!

It is a general drive optimized for wide use in all industrial sectors with powerful sensor-less functions, improved hardware performance and certified high product reliability.



Improved Torque Performance Through Powerful Sensor-less Vector Control Functions

With improved sensor-less vector control functions when compared to our original standard drive, it maintains high torque performance at low speed and efficiently controls the motor.



Various User Convenience Functions and Field Network Support

G100 enables compact installation with DIN rail and side-by-side installation. It supports RJ port connection on the front of the product and greatly enhances the convenience of connecting with peripheral devices. EtherNet/IP, Modbus-TCP, Profibus-DP, Support CANopen option, Built-in RS485



High Product Reliability

The heat-resisting property and intensity of our enclosure have significantly increased, and the insulation distance improved with our design that meets UL61800-5-1 standard.



Intended Use

Used in all industries including metal processing, molding machines, hydraulic / air conditioning equipment, food and beverage / textile machinery, lifts / conveyors and environment / water treatment

- Cutting / Bending / Polishing machines
- Fans / Pumps
- Injection machines / Conveyors
- Dust collectors / Freezers
- Compressors / Blower
- Hoist / Lift

Product Type & Model

LSLV 0022 G100 - 2 E O F N

LS Low Voltage Drive Series

Drive Capacity
0004: 0.4kW - 0220: 22kW

Series Name

Input Voltage
2: 3Ø 200V - 240V / 4: 3Ø 380V - 480V

Keypad
E: LED Keypad

UL Type
O: UL Open Type

EMC Filter
N: Non Built-in EMC filter / F: Built-in EMC filter (C3)

Reactor
N: Non-Reactor

Main Functions

Features	Description	Benefits
Improved Control Performance	Improved sensor-less function and simplified function setting	Powerful torque performance at low speed and high load conditions
Din rail Mounting and Side-by-side Installation	Removable clips to fix the Din-Rail to the product rear and sides; 2mm installation span between products	Fast and simple product installation that takes less than 5 minutes; increased space efficiency of panels
RJ45 Port at the Front Side of the Product	Easily connected to peripheral devices; and parameter can be copied (read/write) without taking the product out from its box	Enhanced convenience in product setting and extended connection with peripheral devices
Various Field Communication Network Support	Modbus, Profibus-DP, CANopen and Ethernet IP communication network support	Connectible with widely-used field networks
Quick Parameter Menu	Frequently-used and useful parameters are set in Quick Parameter Menu (Favorites)	Quick setting with operational convenience according to the customer's application
EMC Filter	Filter that meets the Category C3 standard	Reduced electromagnetic noise and no additional space and expenses for filter installation necessary
Improved Heat-resisting Property and Intensity of Enclosures	The heat-resisting property and intensity have improved with a new material for our enclosures; the enclosures have gotten thicker to prevent damages	Significantly improved product reliability and MTTF 27 years guaranteed
Network Option, Installation Convenience	Communication network operation can be easily connected to the product body without removing its cover; Ethernet 2 port support at the lower part of the option	Easy and fast removable communication network option
Global Standard Requirement	Obtained a certification of CE and new UL 61800-5-1 standard	Product reliability guaranteed (Improved quality of insulation distance)

Control

Control Mode	V/F, slip compensation and sensor-less vector
Frequency Setting Resolution	Digital command: 0.01Hz; analogue command: 0.06Hz (based on 60Hz)
Frequency Level	1% of the peak output frequency
V/F Pattern	Linear, square-law torque reduction, user V/F
Overload Capacity	Heavy duty: 150% 1min, Normal duty: 120% min
Torque Boost	Passive torque boost; auto torque boost

Operation

Operation Mode	Keypad / Terminal Block / Communication Network operation options	
Frequency Setting	Analogue method: -10~10 (V), 0~10 (V), 4~20 (mA); digital method: keypad input	
Operation Function	PID control; 3-wire operation; frequency limit; second motor; forward/backward rotation prohibited; power switching; speed search; power braking; up-down operation; DC braking; frequency jump; slip compensation; auto restart; auto tuning; energy buffering operation; flux braking; and Fire Mode	
Input	Multifunction Terminal (5Points) P1~P5	NPN (Sink) / PNP (Source) options
		Function: Forward operation; backward operation; reset; external trip; emergency trip; jog operation; switching frequency – high, middle, low; acceleration/deceleration by stage – high, middle, low; DC braking at pause; second motor option; frequency increase; frequency decline; 3-wire operation; switching to general operation during PID operation; switching to the body operation during option operation; analogue command fixed frequency; acceleration or deceleration stop option
Output	Multifunctional Relay Terminal	Fault output and inverter operation mode output (N.O., N.C.) AC 250V, 1A or below, DC 30V, 1A or below
	Analogue Output	0~10V Frequency, output current, output voltage, DC voltage options

G100

General Drive

3Ø 200V Class (0.4~22kW)

LSLV□□□□G100-2□□□□□			0004	0008	0015	0022	0040	0055	0075	0110	0150	0185	0220	
Applied Motor	Heavy Duty	(HP)	0.5	1.0	2.0	3.0	5.4	7.5	10	15	20	25	30	
		(kW)	0.4	0.75	1.5	2.2	4.0	5.5	7.5	11	15	18.5	22	
	Normal Duty	(HP)	1.0	2.0	3.0	5.0	7.5	10	15	20	25	30	-	
		(kW)	0.75	1.5	2.2	4.0	5.5	7.5	11	15	18.5	22	-	
Output	Rated Capacity (kVA)	Heavy Duty	1.0	1.9	3.0	4.2	6.5	9.1	12.2	17.9	22.9	28.6	33.5	
		Normal Duty	1.2	2.3	3.8	4.6	6.9	11.4	15.2	21.3	26.7	31.2	-	
	Rated Current (3Ø Input) [A]	Heavy Duty	2.5	5.0	8.0	11.0	17.0	24.0	32.0	47	60	75	88	
		Normal Duty	3.1	6.0	9.6	12.0	18.0	30.0	40.0	56	70	82	-	
	Rated Current (1Ø Input) [A]	Heavy Duty	1.5	2.8	4.6	6.1	9.3	12.8	17.4	26.8	34	41	48	
		Normal Duty	2.0	3.6	5.9	6.7	9.8	16.3	22.0	31	38	45	-	
Rated Frequency (Hz)		0~400Hz (IM Sensorless: 0~120Hz)												
Rated Voltage (V)		3Ø 200~240V												
Input	Rated Voltage (V)		3Ø 200~240VAC (-15%~+10%)											
	Rated Frequency (Hz)		50~60Hz (±5%)											
	Rated Current (A)	Heavy Duty	2.2	4.9	8.4	11.8	18.5	25.8	34.9	53.2	68.4	85.5	101.6	
Normal Duty		3.0	6.3	10.8	13.1	19.4	32.7	44.2	63.8	79.8	94.6	-		
Weight (kg)			1.04	1.06	1.36	1.4	1.89	3.08	3.21	4.84	7.6	11.1	11.18	

3Ø 400V Class (0.4~22kW)

LSLV□□□□G100-4□□□□□			0004	0008	0015	0022	0040	0055	0075	0110	0150	0185	0220	
Applied Motor	Heavy Duty	(HP)	0.5	1.0	2.0	3.0	5.4	7.5	10	15	20	25	30	
		(kW)	0.4	0.75	1.5	2.2	4.0	5.5	7.5	11	15	18.5	22	
	Normal Duty	(HP)	1.0	2.0	3.0	5.0	7.5	10	15	20	25	30	40	
		(kW)	0.75	1.5	2.2	4.0	5.5	7.5	11	15	18.5	22	30	
Output	Rated Capacity (kVA)	Heavy Duty	1.0	1.9	3.0	4.2	6.5	9.1	12.2	18.3	23.6	29.7	34.3	
		Normal Duty	1.5	2.4	3.9	5.3	7.6	12.2	17.5	23.6	29.0	34.3	46.5	
	Rated Current (3Ø Input) (A)	Heavy Duty	1.3	2.5	4.0	5.5	9.0	12.0	16.0	24	31	39	45	
		Normal Duty	2.0	3.1	5.1	6.9	10.0	16.0	23.0	31	38	45	61	
	Rated Current (1Ø Input) (A)	Heavy Duty	0.7	1.4	2.1	2.8	4.9	6.4	8.7	15	18	23	27	
		Normal Duty	1.3	1.9	2.8	3.6	5.4	8.7	12.6	18	23	27	35	
Rated Frequency (Hz)		0~400Hz (IM Sensorless: 0~120Hz)												
Rated Voltage (V)		3Ø 380~480V												
Input	Rated Voltage (V)		3Ø 380~480VAC (-15%~+10%)											
	Rated Frequency (Hz)		50~60Hz (±5%)											
	Rated Current (A)	Heavy Duty	1.1	2.4	4.2	5.9	9.8	12.9	17.5	27.2	35.3	44.5	51.9	
Normal Duty		2.0	3.3	5.5	7.5	10.8	17.5	25.4	35.3	43.3	51.9	70.8		
Weight (kg) (Built-in EMC Filter)			1.02 (1.04)	1.06 (1.08)	1.4 (1.44)	1.42 (1.46)	1.92 (1.98)	3.08 (3.24)	3.12 (3.28)	4.89 (5.04)	4.91 (5.06)	7.63 (7.96)	7.65 (7.98)	

- The motor capacity is calculated with a standard 4-pole motor.
- 200V Class is based on 220V and 400V Class on 440V.
- The rated output current is limited according to the carrier frequency (Cn.04) setting.
- Upon no-load operation to protect the inverter when the motor is open/closed, the output voltage is 20~40% lower than the original voltage. (only for 0.4~4.0kW)

Product Dimension

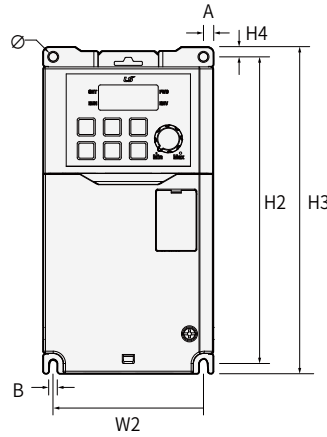
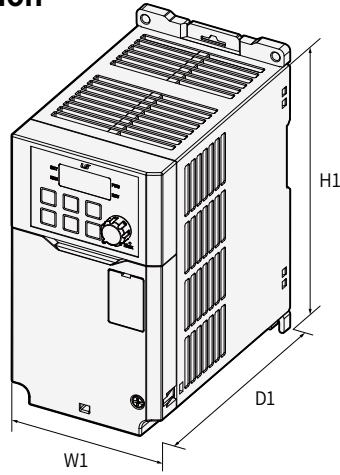

Unit: mm (inches)

Model	W1	W2	H1	H2	H3	H4	D1	A	B	Ø
0004G100-2										
0008G100-2	86.2 (3.39)	76.2 (3.00)	154 (6.06)	154 (6.06)	164 (6.46)	5 (0.20)	131.5 (5.18)	5 (0.20)	4.5 (0.18)	4.5 (0.18)
0004G100-4										
0008G100-4										
0015G100-2										
0022G100-2	101 (3.98)	90 (3.54)	167 (6.57)	167 (6.57)	177 (6.97)	5 (0.20)	150.5 (5.93)	5.5 (0.22)	4.5 (0.18)	4.5 (0.18)
0015G100-4										
0022G100-4										

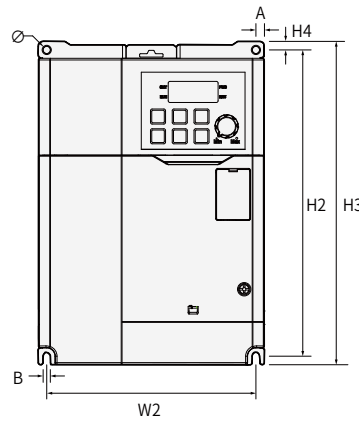
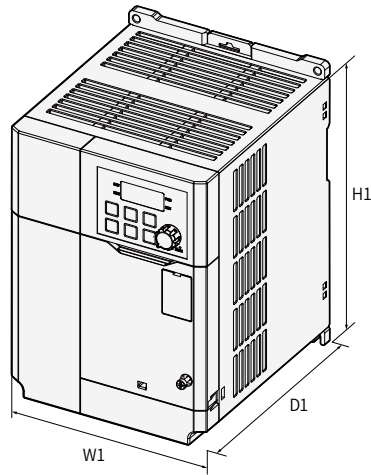

Unit: mm (inches)

Model	W1	W2	H1	H2	H3	H4	D1	A	B	Ø
0040G100-2	135 (5.31)	125 (4.92)	183 (7.20)	183 (7.20)	193 (7.60)	5 (0.20)	150.5 (5.93)	5 (0.20)	4.5 (0.18)	4.5 (0.18)
0040G100-4										
0055G100-2		Top: 162 (6.38)						Top: 9 (0.35)		Ø-1: 4.5 (0.18)
0075G100-2	180 (7.09)		220 (8.66)	229.5 (9.04)	240 (9.45)	5.5 (0.22)	144 (5.67)		4.5 (0.18)	
0055G100-4		Bottom: 170 (6.70)						Bottom: 5 (0.20)		Ø-2: 6 (0.24)
0075G100-4										

G100

General Drive

Product Dimension

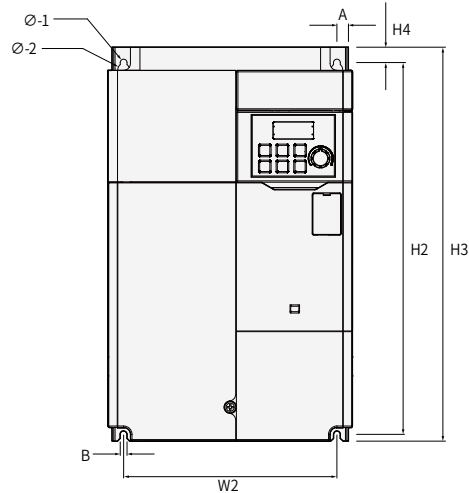
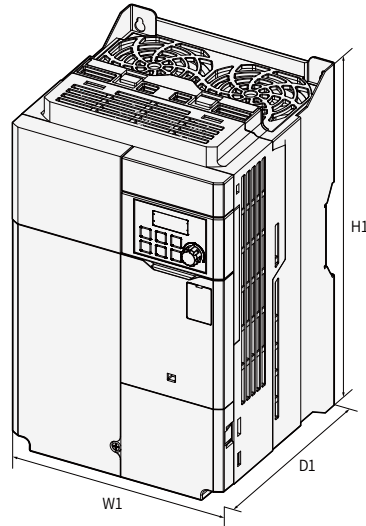

Unit: mm (inches)

Model	W1	W2	H1	H2	H3	H4	D1	A	B	Ø
0110G100-2 0110G100-4 0150G100-4	180 (7.09)	157 (6.18)	290 (11.4)	273.7 (10.8)	290 (11.4)	11.3 (0.44)	173 (6.81)	8.5 (0.33)	5 (0.20)	Ø-1:5(0.20) Ø-2:8.5(0.33)
0150G100-2 0185G100-4 0220G100-4	220 (8.66)	193.8 (7.63)	345 (13.6)	331 (13.0)	345 (13.6)	8 (0.31)	187 (7.36)	10.1 (0.40)	6 (0.24)	Ø-1:6(0.24) Ø-2:11(0.43)
0185G100-2 0220G100-4	260 (10.2)	229.8 (9.05)	400 (15.7)	386 (15.2)	400 (15.7)	8 (0.31)	187 (7.36)	11.4 (0.45)	7 (0.28)	Ø-1:7(0.28) Ø-2:13.5(0.53)



Memo

Energy Saving Drive

Large empty rectangular area for writing the memo content.



S100

Standard Drive



- 1Ø 200V Class 0.4~2.2kW
- 3Ø 200V Class 0.4~15kW
- 3Ø 400V Class 0.4~75kW

IP66

- 1Ø 200V Class 0.4~2.2kW
- 3Ø 200V Class 0.4~15kW
- 3Ø 400V Class 0.4~22kW



S100, a High-performance Standard Drive Boasting Power in a Compact Size

LS standard drive, S100 enhances added values of mechanical devices and equipment with its powerful sensor-less control and a wide range of user-centered functions. It meets the global standard and support various field networks. In particular, IP66 NEMA4X series are fully protected from foreign substances such as fine dust and water sprayed with a high-pressure sprayer.



Efficient Space Utilization

Space efficiency is maximized with its compact size, which is 40% smaller than the original product, and side-by-side installation.



Various Field Network Support

The drive supports the following networks: EtherCAT, EtherNet/IP, Profibus-DP, Modbus TCP, CANopen and etc



IP66/NEMA4X (PDS/Non-PDS)

The drive acquired the highest class IP66 / NEMA4X and it can be used without trouble under poor environment or even when externally exposed.



Intended Use

Applied to the following industries: metal, elevator/escalator, textile machinery, shipping, food and beverage, pulp/paper, coal mine, oil/gas and water treatment

- Hoist (hoist, gantry, trolley)
- Winder (loom, knitting machine)
- Mixer (agitator)
- Compressor
- Centrifugal separator
- General crane
- Conveyor

Product Type & Model

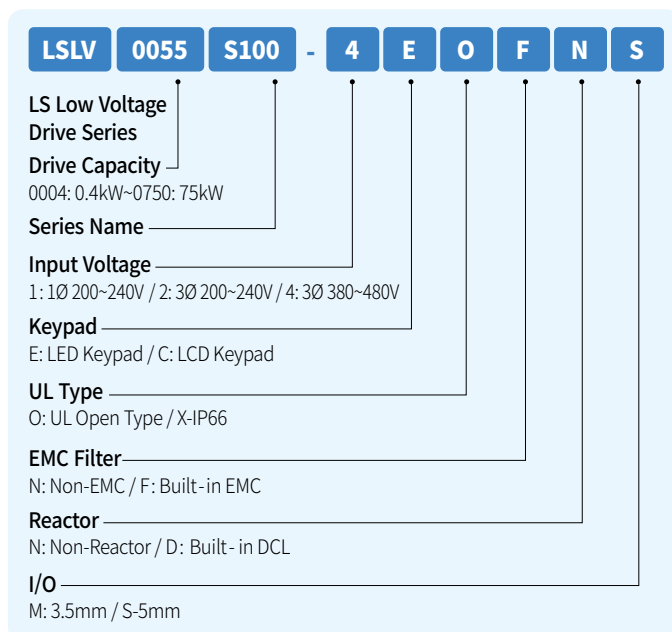

Main Functions

Features	Description	Benefits
Sensor-less Control and Static-type/Rotation-type Auto Tuning	Electric motor constant search is possible without rotating the motor even when the motor is installed at a place where rotation is impossible or when the system is already installed.	Accurate velocity and torque operation
Product Size Reduction and Side-by-side Installation	The product size is reduced up to 60% of its original size; simple replacement of cooling fans; installation span between products is about 2mm	Reduced installation area; and when multiple drives are installed, the control panel size is significantly reduced
Various Field Networks	EtherCAT, PROFINET, Profibus-DP, Ethernet IP, Modbus TCP and CANopen communication network support	Possible to connect to all widely-used field networks; comfortable maintenance of option cards and easy mounting
Compact PLC Function Option	With a combination of various function blocks, a simple PLC sequence programming is realized	High-level control programming with only the drive and without the external PLC
DC Reactor	Built-in DC reactor ※ 400V, 30~75kW	Improved power factor and THD reduction
Safe Torque Off (STO)	Duplexing input circuit is applied; safe input function that meets the following standards: EN ISO 13849-1 PLD and EN 61508 SIL2 (EN60204-1, Stop category 0)	Satisfied the safety standards of systems with a built-in safety design
EMC Filter	Filter satisfying Category C3 (Class A) 2nd Environment CE standard ※ 1-phase 200V 0.4~2.2kW (C2) ※ 3-phase 400V 0.4~75kW (C3)	Reduced electromagnetic noise; additional space and expense for parts not required
IP66 (NEMA 4X) Enclosure Option	Completely protected from foreign substances such fine dust and water sprayed with a high-pressure sprayer	Inverters can be used even when exposed to the poor environment

Control

Control Mode	V/F, slip compensation, sensor-less vector
Frequency Setting Resolution	Digital command: 0.01Hz; analogue command: 0.06Hz (peak frequency: 60Hz)
Frequency Level	1% of the peak output frequency
V/F Pattern	Linear, square-law torque reduction, user V/F
Overload Capacity	Heavy duty: 150% 1min, Normal duty: 120% min
Torque Boost	Passive torque boost; auto torque boost

※ Please contact our salesperson for further details on PM sensor-less functions.

Operation

Operation Mode	Keypad/ Terminal Block / Communication Network options	
Frequency Setting	Analogue method: -10~10 (V), 0~10 (V), 4~20 (mA); digital method: keypad, pulse train input	
Operation Function	PID control; up-down operation; 3-wire operation; DC braking; frequency limit; frequency jump; secondary function; slip compensation; forward/backward rotation prohibited; auto restart; power switch; auto tuning; speed search; energy buffering; power braking; flux braking; leakage-reduced operation; Fire Mode	
Input	Multifunctional Terminal Standard I/O (5Points) Multiple I/O (7Points)	NPN (Sink) / PNP (Source) option Function: Forward operation; backward operation; reset; external trip; emergency trip; jog operation; switching frequency – high, middle, low; acceleration/deceleration by stage – high, middle, low; DC braking upon pause; second motor option; frequency increase; frequency decline; 3-wire operation; switching to general operation during PID operation; switching to body operation during option operation; analogue command fixed frequency; acceleration/deceleration stop option
	Analogue Input	V1: -10~10V, V2: 0~10V / I2 4~20mA options
	Pulse Train	0~32kHz, Low Level: 0~2.5V, High Level: 3.5~12V
Output	Multifunctional Open Collector Terminal	Fault output and drive operation mode output
	Multifunctional Relay Terminal	DC 24V, 50mA or below (N.O., N.C.) AC 250V 1A or below, DC 30V 1A or below
	Analogue Output	0~12Vdc/0~24mA: selectable among frequency, output current, output voltage and DC terminal voltage
	Pulse Train	Up to 32kHz, 10~12 (V)

S100

Standard Drive

1Ø 200V Class (0.4~2.2kW)

LSLV□□□□S100-1□□□□□			0004	0008	0015	0022
Applied Motor	Heavy Duty	(HP)	0.5	1.0	2.0	3.0
		(kW)	0.4	0.75	1.5	2.2
	Normal Duty	(HP)	1.0	2.0	3.0	5.0
		(kW)	0.75	1.5	2.2	3.7
Output	Rated Capacity (kVA)	Heavy Duty	1.0	1.9	3.0	4.2
		Normal Duty	1.2	2.3	3.8	4.6
	Rated Current (A)	Heavy Duty	2.5	5.0	8.0	11.0
		Normal Duty	3.1	6.0	9.6	12.0
	Rated Frequency (Hz)		0~400Hz (IM Sensor-less: 0~120 (Hz))			
	Rated Voltage (V)		3Ø 200~240V			
Rated Voltage (V)		1Ø 200~240VAC (-15%~+10%)				
Input	Rated Frequency (Hz)		50~60Hz (±5%)			
	Rated Current (A)	Heavy Duty	4.4	9.3	15.6	21.7
		Normal Duty	5.8	11.7	19.7	24.0
Weight (kg)	Non-EMC		0.9	1.3	1.5	2.0
	Built-in EMC		1.14	1.76	1.76	2.22

3Ø 200V Class (0.4~15kW)

LSLV□□□□S100-2□□□□□			0004	0008	0015	0022	0037	0040	0055	0075	0110	0150
Applied Motor	Heavy Duty	(HP)	0.5	1.0	2.0	3.0	5.0	5.4	7.5	10.0	15.0	20.0
		(kW)	0.4	0.75	1.5	2.2	3.7	4.0	5.5	7.5	11.0	15.0
	Normal Duty	(HP)	1.0	2.0	3.0	5.0	5.4	7.5	10.0	15.0	20.0	25.0
		(kW)	0.75	1.5	2.2	3.7	4.0	5.5	7.5	11.0	15.0	18.5
Output	Rated Capacity (kVA)	Heavy Duty	1.0	1.9	3.0	4.2	6.1	6.5	9.1	12.2	17.5	22.9
		Normal Duty	1.2	2.3	3.8	4.6	6.9	6.9	11.4	15.2	21.3	26.3
	Rated Current (A) (3Ø Input) (A)	Heavy Duty	2.5	5.0	8.0	11.0	16.0	17.0	24.0	32.0	46.0	60.0
		Normal Duty	3.1	6.0	9.6	12.0	18.0	18.0	30.0	40.0	56.0	69.0
	Rated Current (A) (1Ø Input) (A)	Heavy Duty	1.5	2.8	4.6	6.1	8.8	9.3	13.0	18.0	26.0	33.0
		Normal Duty	1.8	3.3	5.7	6.6	9.9	9.9	16.0	22.0	31.0	38.0
Rated Frequency (Hz)		0~400Hz (IM Sensor-less: 0~120 (Hz))										
Rated Voltage (V)		3Ø 200~240V										
Input	Rated Voltage (V)		3Ø 200~240VAC (-15%~+10%) / 1Ø 200~240VAC (-5%~+10%)									
	Rated Frequency (Hz)		50~60Hz (±5%) (Upon single-phase input, input frequency should only be 60Hz (±5%))									
	Rated Current (A)	Heavy Duty	2.2	4.9	8.4	11.8	17.5	18.5	25.8	34.9	50.8	66.7
Normal Duty		3.0	6.3	10.8	13.1	19.4	19.4	32.7	44.2	62.3	77.2	
Weight (kg)	Non-EMC		0.9	0.9	1.3	1.5	2.0	2.0	3.1	3.1	4.4	6.9
	Built-in EMC		-	-	-	-	-	-	-	-	-	-

- The motor capacity is calculated with a 4-pole standard motor.
- 200V Class is based on 220V, and 400V Class on 440V.
- The rated output current is limited according to the carrier frequency (Cn.04) setting.
- Upon no-load operation to protect the drive when the motor is open/closed, the output voltage is 20~40% lower than the original voltage. (only for 0.4~4.0kW)
- Dual rating is supported for products, excluding IP66/NEMA 4X.

3Ø 400V Class (0.4~22kW)

LSLV□□□□S100-4□□□□□			0004	0008	0015	0022	0037	0040	0055	0075	0110	0150	0185	0220	
Applied Motor	Heavy Duty	(HP)	0.5	1.0	2.0	3.0	5.0	5.4	7.5	10.0	15.0	20.0	25.0	30.0	
		(kW)	0.4	0.75	1.5	2.2	3.7	4.0	5.5	7.5	11.0	15.0	18.5	22.0	
	Normal Duty	(HP)	1.0	2.0	3.0	5.0	5.4	7.5	10.0	15.0	20.0	25.0	30.0	40.0	
		(kW)	0.75	1.5	2.2	3.7	4.0	5.5	7.5	11.0	15.0	18.5	22.0	30.0	
Output	Rated Capacity (kVA)	Heavy Duty	1.0	1.9	3.0	4.2	6.1	6.9	9.1	12.2	18.3	22.9	29.7	34.3	
		Normal Duty	1.5	2.4	3.9	5.3	7.6	7.6	12.2	17.5	22.9	29.0	33.5	44.2	
	Rated Current (A) (3Ø Input) (A)	Heavy Duty	1.3	2.5	4.0	5.5	8.0	9.0	12.0	16.0	24.0	30.0	39.0	45.0	
		Normal Duty	2.0	3.1	5.1	6.9	10.0	10.0	16.0	23.0	30.0	38.0	44.0	58.0	
	Rated Current (A) (1Ø Input) (A)	Heavy Duty	0.8	1.5	2.3	3.1	4.8	5.4	7.1	9.5	15.0	18.0	23.0	27.0	
		Normal Duty	1.3	1.9	3.0	3.9	5.9	5.9	9.5	14.0	18.0	23.0	27.0	35.0	
	Rated Frequency (Hz)		0~400Hz (IM Sensor-less: 0~120 (Hz))												
Rated Voltage (V)		3Ø 380~480V													
Input	Rated Voltage (V)		3Ø 380~480VAC (-15%~+10%) / 1Ø 200~240VAC (-5%~+10%)												
	Rated Frequency (Hz)		50~60Hz (±5%) (Upon single-phase input, input frequency should only be 60Hz (±5%))												
	Rated Current(A)	Heavy Duty	1.1	2.4	4.2	5.9	8.7	9.8	12.9	17.5	26.5	33.4	43.6	50.7	
		Normal Duty	2.0	3.3	5.5	7.5	10.8	10.8	17.5	25.4	33.4	42.5	49.5	65.7	
Weight (kg)	Non-EMC		0.9	0.9	1.3	1.5	2.0	2.0	-	-	-	-	-	-	
	Built-in EMC		1.18	1.18	1.77	1.80	2.23	2.23	3.3	3.4	4.6	4.8	7.5	7.5	

3Ø 400V Class (30~75kW)

LSLV□□□□S100-4□□□□□			0300	0370	0450	0550	0750
Applied Motor	Heavy Duty	(HP)	40.0	50.0	60.0	75.0	100.0
		(kW)	30.0	37.0	45.0	55.0	75.0
	Normal Duty	(HP)	50.0	60.0	75.0	100.0	120.0
		(kW)	37.0	45.0	55.0	75.0	90.0
Output	Rated Capacity (kVA)	Heavy Duty	46.0	57.0	69.0	84.0	116.0
		Normal Duty	55.0	67.0	78.0	106.0	126.0
	Rated Current (A) (3Ø Input) (A)	Heavy Duty	61.0	75.0	91.0	110.0	152.0
		Normal Duty	75.0	91.0	107.0	142.0	169.0
	Rated Current (A) (1Ø Input) (A)	Heavy Duty	32.0	39.0	47.0	57.0	78.0
		Normal Duty	39.0	47.0	55.0	73.0	87.0
Rated Frequency (Hz)		0~400Hz (IM Sensor-less: 0~120 (Hz))					
Rated Voltage (V)		3Ø 380~480V					
Input	Rated Voltage (V)		3Ø 380~480VAC (-15%~+10%) / 1Ø 200~240VAC (-5%~+10%)				
	Rated Frequency (Hz)		50~60Hz (±5%) (Upon single-phase input, input frequency should only be 60Hz (±5%))				
	Rated Current (A)	Heavy Duty	56.0	69.0	85.0	103.0	143.0
		Normal Duty	69.0	85.0	100.0	134.0	160.0
Weight (kg)	Non-EMC		25.0	34.0	34.0	43	43
	Built-in EMC		26.0	35.0	35.0		

• The motor capacity is calculated with a 4-pole standard motor.

• 200V Class is based on 220V, and 400V Class on 440V.

• The rated output current is limited according to the carrier frequency (Cn.04) setting.

• Upon no-load operation to protect the drive when the motor is open/closed, the output voltage is 20~40% lower than the original voltage. (only for 0.4~4.0kW)

• Dual rating is supported for products, excluding IP66/NEMA 4X.

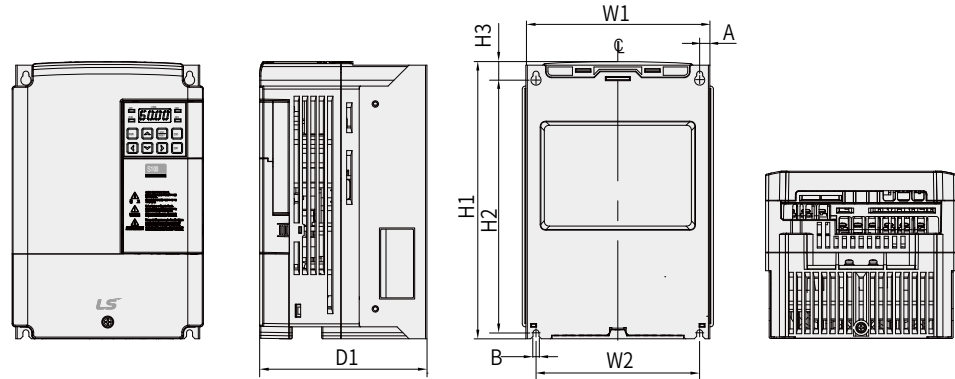
S100**Standard Drive****Product Dimension****IP20 Type**

Unit: mm (inches)

Model	W1	W2	H1	H2	H3	D1	A	B	Ø
LSLV0004S100-2	68 [2.68]	61.1 [2.41]	128 [5.04]	119 [4.69]	5 [0.20]	123 [4.84]	3.5 [0.14]	4 [0.16]	4.2 [0.17]
LSLV0004S100-4	68 [2.68]	61.1 [2.41]	128 [5.04]	119 [4.69]	5 [0.20]	123 [4.84]	3.5 [0.14]	4 [0.16]	4.2 [0.17]
LSLV0004S100-1	68 [2.68]	61.1 [2.41]	128 [5.04]	119 [4.69]	5 [0.20]	128 [5.04]	3.5 [0.14]	4 [0.16]	4 [0.16]
LSLV0008S100-2	68 [2.68]	61.1 [2.41]	128 [5.04]	119 [4.69]	5 [0.20]	128 [5.04]	3.5 [0.14]	4 [0.16]	4 [0.16]
LSLV0008S100-4	68 [2.68]	61.1 [2.41]	128 [5.04]	119 [4.69]	5 [0.20]	128 [5.04]	3.5 [0.14]	4 [0.16]	4 [0.16]
LSLV0008S100-1	100 [3.94]	91 [3.58]	128 [5.04]	120 [4.72]	4.5 [0.18]	130 [5.12]	4.5 [0.18]	4.5 [0.18]	4.5 [0.18]
LSLV0015S100-2	100 [3.94]	91 [3.58]	128 [5.04]	120 [4.72]	4.5 [0.18]	130 [5.12]	4.5 [0.18]	4.5 [0.18]	4.5 [0.18]
LSLV0015S100-4	100 [3.94]	91 [3.58]	128 [5.04]	120 [4.72]	4.5 [0.18]	130 [5.12]	4.5 [0.18]	4.5 [0.18]	4.5 [0.18]
LSLV0015S100-1	100 [3.94]	91 [3.58]	128 [5.04]	120 [4.72]	4.5 [0.18]	145 [5.71]	4.5 [0.18]	4.5 [0.18]	4.5 [0.18]
LSLV0022S100-2	100 [3.94]	91 [3.58]	128 [5.04]	120 [4.72]	4.5 [0.18]	145 [5.71]	4.5 [0.18]	4.5 [0.18]	4.5 [0.18]
LSLV0022S100-4	100 [3.94]	91 [3.58]	128 [5.04]	120 [4.72]	4.5 [0.18]	145 [5.71]	4.5 [0.18]	4.5 [0.18]	4.5 [0.18]
LSLV0022S100-1	140 [5.51]	132.2 [5.21]	128 [5.04]	120.7 [4.75]	3.7 [0.15]	145 [5.71]	3.9 [0.15]	4.4 [0.17]	4.5 [0.18]
LSLV0037S100-2	140 [5.51]	132.2 [5.21]	128 [5.04]	120.7 [4.75]	3.7 [0.15]	145 [5.71]	3.9 [0.15]	4.4 [0.17]	4.5 [0.18]
LSLV0037S100-4	140 [5.51]	132.2 [5.21]	128 [5.04]	120.7 [4.75]	3.7 [0.15]	145 [5.71]	3.9 [0.15]	4.4 [0.17]	4.5 [0.18]
LSLV0040S100-2	140 [5.51]	132.2 [5.21]	128 [5.04]	120.7 [4.75]	3.7 [0.15]	145 [5.71]	3.9 [0.15]	4.4 [0.17]	4.5 [0.18]
LSLV0040S100-4	140 [5.51]	132.2 [5.21]	128 [5.04]	120.7 [4.75]	3.7 [0.15]	145 [5.71]	3.9 [0.15]	4.4 [0.17]	4.5 [0.18]
LSLV0004S100-1 ²⁾	68 [2.68]	63.5 [2.5]	180 [7.09]	170.5 [6.71]	5 [0.20]	130 [5.12]	4.5 [0.18]	4.5 [0.18]	4.2 [0.17]
LSLV0004S100-4 ²⁾	68 [2.68]	63.5 [2.5]	180 [7.09]	170.5 [6.71]	5 [0.20]	130 [5.12]	4.5 [0.18]	4.5 [0.18]	4.2 [0.17]
LSLV0008S100-4 ²⁾	68 [2.68]	63.5 [2.5]	180 [7.09]	170.5 [6.71]	5 [0.20]	130 [5.12]	4.5 [0.18]	4.5 [0.18]	4.2 [0.17]
LSLV0008S100-1 ¹⁾	100 [3.94]	91 [3.59]	180 [7.09]	170 [6.69]	5 [0.20]	140 [5.51]	4.5 [0.18]	4.5 [0.18]	4.2 [0.17]
LSLV0015S100-1 ¹⁾	100 [3.94]	91 [3.59]	180 [7.09]	170 [6.69]	5 [0.20]	140 [5.51]	4.5 [0.18]	4.5 [0.18]	4.2 [0.17]
LSLV0015S100-4 ¹⁾	100 [3.94]	91 [3.59]	180 [7.09]	170 [6.69]	5 [0.20]	140 [5.51]	4.5 [0.18]	4.5 [0.18]	4.2 [0.17]
LSLV0022S100-4 ²⁾	100 [3.94]	91 [3.59]	180 [7.09]	170 [6.69]	5 [0.20]	140 [5.51]	4.5 [0.18]	4.5 [0.18]	4.2 [0.17]
LSLV0022S100-1 ¹⁾	140 [5.51]	132 [5.20]	180 [7.09]	170 [6.69]	5 [0.20]	140 [5.51]	4 [0.18]	4 [0.18]	4.2 [0.17]
LSLV0037S100-4 ²⁾	140 [5.51]	132 [5.20]	180 [7.09]	170 [6.69]	5 [0.20]	140 [5.51]	4 [0.18]	4 [0.18]	4.2 [0.17]
LSLV0040S100-4 ²⁾	140 [5.51]	132 [5.20]	180 [7.09]	170 [6.69]	5 [0.20]	140 [5.51]	4 [0.18]	4 [0.18]	4.2 [0.17]
LSLV0055S100-2	160 [6.30]	137 [5.39]	232 [9.13]	216.5 [8.52]	10.5 [0.41]	140 [5.51]	5 [0.20]	5 [0.20]	-
LSLV0075S100-2	160 [6.30]	137 [5.39]	232 [9.13]	216.5 [8.52]	10.5 [0.41]	140 [5.51]	5 [0.20]	5 [0.20]	-
LSLV0055S100-4 ²⁾	160 [6.30]	137 [5.39]	232 [9.13]	216.5 [8.52]	10.5 [0.41]	140 [5.51]	5 [0.20]	5 [0.20]	-
LSLV0075S100-4 ²⁾	160 [6.30]	137 [5.39]	232 [9.13]	216.5 [8.52]	10.5 [0.41]	140 [5.51]	5 [0.20]	5 [0.20]	-
LSLV0110S100-2	180 [7.09]	157 [6.18]	290 [11.4]	273.7 [10.8]	11.3 [0.44]	163 [6.42]	5 [0.20]	5 [0.20]	-
LSLV0110S100-4 ²⁾	180 [7.09]	157 [6.18]	290 [11.4]	273.7 [10.8]	11.3 [0.44]	163 [6.42]	5 [0.20]	5 [0.20]	-
LSLV0150S100-4 ²⁾	180 [7.09]	157 [6.18]	290 [11.4]	273.7 [10.8]	11.3 [0.44]	163 [6.42]	5 [0.20]	5 [0.20]	-
LSLV0150S100-2	220 [8.66]	193.8 [7.63]	350 [13.8]	331 [13.0]	13 [0.51]	187 [7.36]	6 [0.24]	6 [0.24]	-
LSLV0185S100-4 ²⁾	220 [8.66]	193.8 [7.63]	350 [13.8]	331 [13.0]	13 [0.51]	187 [7.36]	6 [0.24]	6 [0.24]	-
LSLV0220S100-4 ²⁾	220 [8.66]	193.8 [7.63]	350 [13.8]	331 [13.0]	13 [0.51]	187 [7.36]	6 [0.24]	6 [0.24]	-
LSLV0300S100-4 ²⁾	275 [10.8]	232 [9.13]	450 [17.7]	428.5 [16.87]	14 [0.55]	284 [11.2]	7 [0.28]	7 [0.28]	-
LSLV0370S100-4 ²⁾	325 [12.8]	282 [11.10]	510 [20.1]	486.5 [19.15]	16 [0.63]	284 [11.2]	7 [0.28]	7 [0.28]	-
LSLV0450S100-4 ²⁾	325 [12.8]	282 [11.10]	510 [20.1]	486.5 [19.15]	16 [0.63]	284 [11.2]	7 [0.28]	7 [0.28]	-
LSLV0550S100-4	325 [12.8]	275 [10.83]	550 [21.7]	524.5 [20.65]	16 [0.63]	309 [12.2]	9 [0.35]	9 [0.35]	-
LSLV0750S100-4	325 [12.8]	275 [10.83]	550 [21.7]	524.5 [20.65]	16 [0.63]	309 [12.2]	9 [0.35]	9 [0.35]	-

1) EMC filter built-in class2 2) EMC filter built-in class3

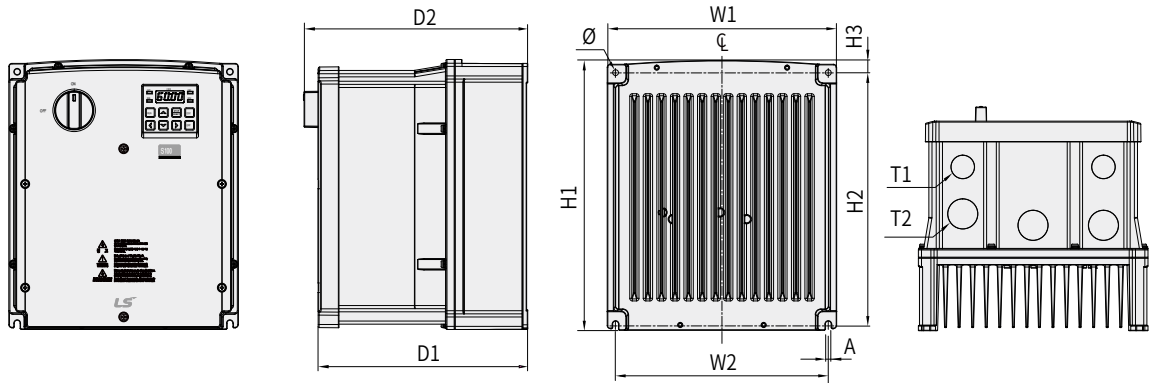

IP66 Type

Unit: mm (inches)

Model	W1	W2	H1	H2	H3	D1	D2	A	Ø	T1	T2
LSLV0004S100-2X	180 (7.09)	170 (6.69)	256.6 (10.10)	245 (9.65)	8.2 (0.32)	174.2 (6.86)	188.2 (7.41)	4.5 (0.18)	4.5 (0.18)	22.3 (0.88)	-
LSLV0008S100-2X	180 (7.09)	170 (6.69)	256.6 (10.10)	245 (9.65)	8.2 (0.32)	174.2 (6.86)	188.2 (7.41)	4.5 (0.18)	4.5 (0.18)	22.3 (0.88)	-
LSLV0004S100-4X ¹⁾	180 (7.09)	170 (6.69)	256.6 (10.10)	245 (9.65)	8.2 (0.32)	174.2 (6.86)	188.2 (7.41)	4.5 (0.18)	4.5 (0.18)	22.3 (0.88)	-
LSLV0008S100-4X ¹⁾	180 (7.09)	170 (6.69)	256.6 (10.10)	245 (9.65)	8.2 (0.32)	174.2 (6.86)	188.2 (7.41)	4.5 (0.18)	4.5 (0.18)	22.3 (0.88)	-
LSLV0015S100-2X	220 (8.66)	204 (8.03)	258.8 (10.19)	241 (9.49)	11.8 (0.46)	201 (7.91)	215 (8.46)	5.5 (0.22)	5.5 (0.22)	22.3 (0.88)	28.6 (1.13)
LSLV0022S100-2X	220 (8.66)	204 (8.03)	258.8 (10.19)	241 (9.49)	11.8 (0.46)	201 (7.91)	215 (8.46)	5.5 (0.22)	5.5 (0.22)	22.3 (0.88)	28.6 (1.13)
LSLV0037S100-2X	220 (8.66)	204 (8.03)	258.8 (10.19)	241 (9.49)	11.8 (0.46)	201 (7.91)	215 (8.46)	5.5 (0.22)	5.5 (0.22)	22.3 (0.88)	28.6 (1.13)
LSLV0040S100-2X	220 (8.66)	204 (8.03)	258.8 (10.19)	241 (9.49)	11.8 (0.46)	201 (7.91)	215 (8.46)	5.5 (0.22)	5.5 (0.22)	22.3 (0.88)	28.6 (1.13)
LSLV0015S100-4X ¹⁾	220 (8.66)	204 (8.03)	258.8 (10.19)	241 (9.49)	11.8 (0.46)	201 (7.91)	215 (8.46)	5.5 (0.22)	5.5 (0.22)	22.3 (0.88)	28.6 (1.13)
LSLV0022S100-4X ¹⁾	220 (8.66)	204 (8.03)	258.8 (10.19)	241 (9.49)	11.8 (0.46)	201 (7.91)	215 (8.46)	5.5 (0.22)	5.5 (0.22)	22.3 (0.88)	28.6 (1.13)
LSLV0037S100-4X ¹⁾	220 (8.66)	204 (8.03)	258.8 (10.19)	241 (9.49)	11.8 (0.46)	201 (7.91)	215 (8.46)	5.5 (0.22)	5.5 (0.22)	22.3 (0.88)	28.6 (1.13)
LSLV0040S100-4X ¹⁾	220 (8.66)	204 (8.03)	258.8 (10.19)	241 (9.49)	11.8 (0.46)	201 (7.91)	215 (8.46)	5.5 (0.22)	5.5 (0.22)	22.3 (0.88)	28.6 (1.13)
LSLV0055S100-2X	250 (9.84)	232 (9.13)	328 (12.91)	308 (12.13)	11 (0.43)	227.2 (8.94)	241.2 (9.50)	6 (0.24)	6 (0.24)	22.3 (0.88)	28.6 (1.13)
LSLV0075S100-2X	250 (9.84)	232 (9.13)	328 (12.91)	308 (12.13)	11 (0.43)	227.2 (8.94)	241.2 (9.50)	6 (0.24)	6 (0.24)	22.3 (0.88)	28.6 (1.13)
LSLV0055S100-4X ¹⁾	250 (9.84)	232 (9.13)	328 (12.91)	308 (12.13)	11 (0.43)	227.2 (8.94)	241.2 (9.50)	6 (0.24)	6 (0.24)	22.3 (0.88)	28.6 (1.13)
LSLV0075S100-4X ¹⁾	250 (9.84)	232 (9.13)	328 (12.91)	308 (12.13)	11 (0.43)	227.2 (8.94)	241.2 (9.50)	6 (0.24)	6 (0.24)	22.3 (0.88)	28.6 (1.13)
LSLV0110S100-2X	260 (10.24)	229 (9.02)	399.6 (15.73)	377 (14.84)	14.6 (0.57)	245.4 (9.66)	259.6 (10.22)	6 (0.24)	-	22.3 (0.88)	34.9 (1.37)
LSLV0150S100-2X	300 (11.81)	270.8 (10.66)	460 (18.11)	436.5 (17.19)	15.5 (0.61)	250 (9.84)	264 (10.39)	6 (0.24)	-	22.3 (0.88)	44.5 (1.75)
LSLV0110S100-4X ¹⁾	260 (10.24)	229 (9.02)	399.6 (15.73)	377 (14.84)	14.6 (0.57)	245.4 (9.66)	259.6 (10.22)	6 (0.24)	-	22.3 (0.88)	34.9 (1.37)
LSLV0150S100-4X ¹⁾	260 (10.24)	229 (9.02)	399.6 (15.73)	377 (14.84)	14.6 (0.57)	245.4 (9.66)	259.6 (10.22)	6 (0.24)	-	22.3 (0.88)	34.9 (1.37)
LSLV0185S100-4X ¹⁾	300 (11.81)	270.8 (10.66)	460 (18.11)	436.5 (17.19)	15.5 (0.61)	250 (9.84)	264 (10.39)	6 (0.24)	-	22.3 (0.88)	44.5 (1.75)
LSLV0220S100-4X ¹⁾	300 (11.81)	270.8 (10.66)	460 (18.11)	436.5 (17.19)	15.5 (0.61)	250 (9.84)	264 (10.39)	6 (0.24)	-	22.3 (0.88)	44.5 (1.75)

1) EMC filter built-in class3

H100

Fan & Pump Drive



- 3Ø 200V 0.75~18.5kW
- 3Ø 400V 0.75~500kW



Scan the QR code marked on the product cover for further details on this product.

Significant Energy Saving With LS Drive Solutions

This product is developed to build an environment-friendly system that realizes significant energy saving in the industrial field of fans/pumps and water treatment based on the leading drive solutions.



Safe System Control

For safe pump operation, the following functions are provided for users: Soft Fill; start and stop slope adjustment; valve deceleration time setting; multi-motor control; and scheduling operation.



Optimized for HVAC and Water Treatment

User-friendly functions for convenient use of fans/pumps such as pump clean, auxiliary motor PID compensation and load tuning.



Intended Use

Applied to the following industries: building, metal, pulp/paper, coal mine, oil/gas and water treatment; (fan/pump, dryer)



Marine Certifications

ABS, BV, CCS, DNV/GL, KR, LR, NK, RINA, RS



GOOD DESIGN
산업통상자원부산업



Product Type & Model

LSLV 0008 H100 - 4 C O F N

LS Low Voltage Drive Series

Drive Capacity
0008: 0.75kW~5000: 500kW

Series Name

Input Voltage
2: 3Ø 200~240 (V)
4: 3Ø 380~480 (V)

Keypad Type
C: LCD Keypad

UL Type
O: UL Open

EMC Filter
F: Built-in EMC
N: Non EMC

Reactor
D: Built-in DC Reactor
N: Non DC Reactor

Main Functions

Features	Description	Benefits
HVAC-only Function	Multi Motor Control, PID operation, flow (flux) compensation, scheduling operation	Optimized operation for HVAC load
Fan/Pump Protection Function	Protective functions include Soft Fill; valve deceleration time setting; pump clean; pipe breakage level detection; Underload Detection; lubrication Fire Mode	Support for optimized fan/pump system performance; extended life of machinery with load; and reduced maintenance cost
Built-in EMC Filter	400V 5.5~30kW, 110~500kW built-in(C3) 400V 37~500kW built-in option (C3) ※ With a filter, 75~90kW meets the EMC standard	Reduced electromagnetic noise and additional space and cost for parts unnecessary
Various Field Networks	RS-485 and BACnet network support for general HVAC system; Modbus-RTU, Metasys N2 and LonWorks options	Connectable with all widely-used field networks; simple maintenance of option cards and easier mounting
Reduced Product Size and Side-by-Side Installation	The product size is reduced up to 60% of its original size; simple replacement of cooling fans; installation span between products is about 2mm	Reduced installation area; and when installing multiple motors, the control panel size is significantly reduced
DC Reactor	400V 37~500kW products have a built-in DC reactor	Improved power factor; and THD reduction
Global Standard Requirement	UL Plenum-Rated 110~500kW; obtained a certificate of new UL 61800-5-1 (improved quality of insulation distance)	Product reliability enhanced as it meets the new global standard

Control

Control Mode	V/F, slip compensation
Frequency Setting Resolution	Digital command: 0.01Hz Analogue command: 0.06Hz (based on 60Hz)
Frequency Level	1% of the peak output frequency
V/F Pattern	Linear, square-law torque reduction, user V/F
Overload Capacity	5.5~90kW rated current: 120% 1min 110~500kW rated current: 110% 1min
Torque Boost	Passive torque boost; auto torque boost

Operation

Operation Mode	Keypad, Terminal Block, Communication Network options	
Frequency Setting	Analogue method: -10 ~ 10V, 0 ~ 10V, 0 ~ 20mA Digital method: keypad, pulse train input	
Operation Function	PID control; 3-wire operation; frequency limit; secondary function; forward/backward rotation prohibited; power switch; speed search; power brake; leakage-reduced operation; up-down operation; DC braking; frequency jump; slip compensation; auto restart; auto tuning; energy buffering operation; flux braking; energy saving operation	
Input	Multifunctional Terminal (7Points)	PNP(Source), NPN(Sink) options According to the parameter setting of IN-65~71 codes, the following functions can be set. Forward operation; reset; emergency trip; switching frequency – high/middle/low; DC braking upon stop; frequency increase; 3-wire operation; acceleration or deceleration stop; MMC interlock; backward operation; external trip; job operation; acceleration/deceleration by stage – high/middle/low; second motor option; frequency decline; analogue command fixed frequency; switching to the general operation during PID operation; Pre Heat; pump cleaning; RTC (time event function)
	Pulse Train	0~32kHz, Low Level: 0~0.8V, High Level: 3.5~12V
Output	Multifunctional Open Collector Terminal	DC26V, 50mA or below
	Fault Relay Terminal	Fault output and drive operation mode output N.O.: AC 250V, 2A or below; DC 30V, 3A or below N.C.: AC 250V, 1A or below; DC 30V, 1A or below
	Multifunctional Relay Terminal	AC250V, 5A or below, DC30V, 5A or below
	Analogue Output	0~12Vdc(0~20mA): Frequency, output current, output voltage, DC voltage options
	Pulse Train	Up to 32kHz, 0~12V

H100

Fan & Pump Drive

3Ø 200V Class (0.75~18.5kW)

LSLV□□□□H100-2□□□□□		0008	0015	0022	0037	0055	0075	0110	0150	0185
Applied Motor	HP	1.0	2.0	3.0	5.0	7.5	10	15	20	25
	kW	0.75	1.5	2.2	3.7	5.5	7.5	11	15	18.5
Output	Rated Capacity (kVA)	1.9	3.0	4.5	6.1	8.4	11.4	16.0	21.3	26.3
	Rated Current (A)	5	8	12	16	22	30	42	56	69
	Rated Frequency (Hz)	0~400Hz								
	Rated Voltage (V)	3Ø 200~240V								
Input	Rated Voltage (V)	3Ø 200~240VAC (-15%~+10%)								
	Rated Frequency (Hz)	50~60Hz (±5%)								
	Rated Current (A)	4.9	8.4	12.9	17.5	23.7	32.7	46.4	62.3	77.2
Weight (kg)		3.3	3.3	3.3	3.3	3.3	3.3	3.3	4.6	7.1

3Ø 400V Class (0.75~22kW)

LSLV□□□□H100-4□□□□□		0008	0015	0022	0037	0055	0075	0110	0150	0185	0220
Applied Motor	HP	1.0	2.0	3.0	5.0	7.5	10	15	20	25	30
	kW	0.75	1.5	2.2	3.7	5.5	7.5	11	15	18.5	22
Output	Rated Capacity (kVA)	1.9	3.0	4.5	6.1	9.1	12.2	18.3	23.0	29.0	34.3
	Rated Current (A)	2.5	4	6	8	12	16	24	30	38	45
	Rated Frequency (Hz)	0~400Hz									
	Rated Voltage (V)	3Ø 380~480V									
Input	Rated Voltage (V)	3Ø 380~480VAC (-15%~+10%)									
	Rated Frequency (Hz)	50~60Hz (±5%)									
	Rated Current (A)	2.4	4.2	6.5	8.7	12.2	17.5	26.5	33.4	42.5	50.7
Weight (kg)		3.3	3.3	3.3	3.3	3.3	3.3	3.4	4.6	4.8	7.5

3Ø 400V Class (30~90kW)

LSLV□□□□H100-4□□□□□		0300	0370	0450	0550	0750	0900	
Applied Motor	HP	40	50	60	75	100	125	
	kW	30	37	45	55	75	90	
Output	Rated Capacity (kVA)	46.5	57.1	69.4	82.0	108.2	128.8	
	Rated Current (A)	61	75	91	107	142	169	
	Rated Frequency (Hz)	0~400Hz						
	Rated Voltage (V)	3Ø 380~480V						
Input	Rated Voltage (V)	3Ø 380~480VAC (-15%~+10%)						
	Rated Frequency (Hz)	50~60Hz (±5%)						
	Rated Current (A)	69.1	69.3	84.6	100.1	133.6	160.0	
Weight (kg)/EMC Built-in		7.5	26	35	35	43		
Weight (kg)/Non EMC		-	25	34	34			

3Ø 400V Class (110~500kW)

LSLV□□□□H100-4□□□□□		1100	1320	1600	1850	2200	2500	3150	3550	4000	5000
Applied Motor	HP	150	200	250	300	350	400	500	550	650	800
	kW	110	132	160	185	220	250	315	355	400	500
Output	Rated Capacity (kVA)	170	201	248	282	329	367	467	520	587	733
	Rated Current (A)	223	264	325	370	432	481	613	683	770	962
	Rated Frequency (Hz)	0~400Hz									
	Rated Voltage (V)	3Ø 380~500V									
Input	Rated Voltage (V)	3Ø 380~500VAC (-15%~+10%)									
	Rated Frequency (Hz)	50~60Hz (±5%)									
	Rated Current (A)	215.1	254.6	315.3	358.9	419.1	469.3	598.1	666.4	751.3	938.6
Weight (kg)		55.8	55.8	74.7	74.7	120.0	120.0	185.5	185.5	185.5	265

- The motor capacity is calculated with a standard 4-pole electric motor.
- 200V Class is based on 220V and 400V Class on 440V.
- The rated output current is limited according to carrier frequency (CON-04) setting.
- 400V 5.5~30kW capacity products have built-in EMC filters.
- 400V 37~55kW capacity products have an option to include built-in EMC filters.
- 400V 75~90kW capacity products satisfy the EMC standard with a separate filter.
- The overload tolerance of 200V 5.5~18.5kW and 400V 5.5~90kW products is 120%.
- 400V 110~500kW capacity products have built-in EMC filters.
- The overload tolerance of 400V 110~500kW products is 110%.

Product Dimension

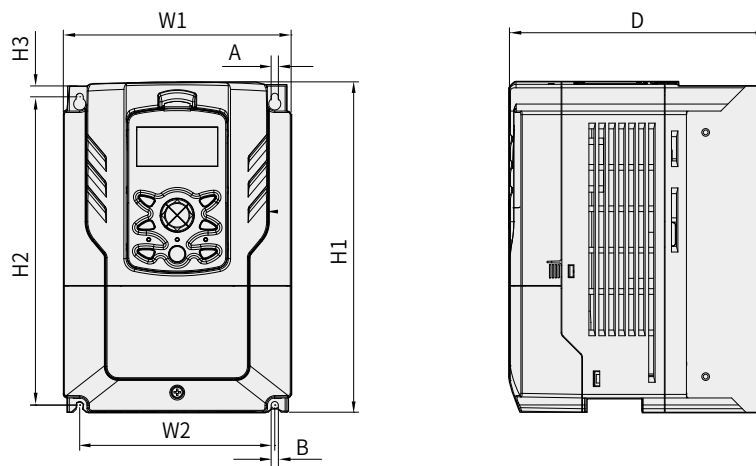

IP20 Type

Unit: mm (inches)

Model	W1	W2	H1	H2	H3	D	A	B
LSLV0008H100-2	160 (6.30)	137 (5.39)	232 (9.13)	216.5 (8.52)	10.5 (0.41)	181 (7.13)	5 (0.20)	5 (0.20)
LSLV0015H100-2								
LSLV0022H100-2								
LSLV0037H100-2								
LSLV0055H100-2								
LSLV0075H100-2								
LSLV0110H100-2								
LSLV0008H100-4								
LSLV0015H100-4								
LSLV0022H100-4								
LSLV0037H100-4	180 (7.09)	157 (6.18)	290 (44.42)	273.7 (10.78)	11.3 (0.45)	205.3 (8.08)	5 (0.20)	5 (0.20)
LSLV0055H100-4								
LSLV0075H100-4								
LSLV0110H100-4								
LSLV0150H100-2								
LSLV0150H100-4								
LSLV0185H100-4								
LSLV0185H100-2								
LSLV0220H100-4								
LSLV0300H100-4								
LSLV0370H100-4	220 (8.66)	193.8 (7.63)	350 (13.78)	331 (13.03)	13 (0.51)	223.2 (8.79)	6 (0.24)	6 (0.24)
LSLV0450H100-4								
LSLV0550H100-4								
LSLV0750H100-4								
LSLV0900H100-4								
LSLV1100H100-4								
LSLV1320H100-4								
LSLV1600H100-4								
LSLV1850H100-4								
LSLV1850H100-4								
LSLV0450H100-4	275 (10.83)	232 (9.13)	450 (17.72)	428.5 (16.87)	14 (0.55)	284 (11.18)	7 (0.28)	7 (0.28)
LSLV0550H100-4								
LSLV0750H100-4								
LSLV0900H100-4								
LSLV1100H100-4								
LSLV1320H100-4								
LSLV1600H100-4								
LSLV1850H100-4								
LSLV1850H100-4								
LSLV1850H100-4								
LSLV0750H100-4	325 (12.08)	282 (11.10)	510 (20.08)	486.5 (19.15)	16 (0.63)	309 (12.80)	7 (0.28)	7 (0.28)
LSLV0900H100-4								
LSLV1100H100-4								
LSLV1320H100-4								
LSLV1600H100-4								
LSLV1850H100-4								
LSLV1850H100-4								
LSLV1850H100-4								
LSLV1850H100-4								
LSLV1850H100-4								
LSLV0900H100-4	300 (11.81)	200 (7.87)	706 (27.80)	685.5 (26.99)	9.5 (0.37)	386 (15.20)	9 (0.35)	9 (0.35)
LSLV1100H100-4								
LSLV1320H100-4								
LSLV1600H100-4								
LSLV1850H100-4								
LSLV1850H100-4								
LSLV1850H100-4								
LSLV1850H100-4								
LSLV1850H100-4								
LSLV1850H100-4								
LSLV1600H100-4	380 (14.96)	300 (11.81)	705 (27.76)	685.5 (26.99)	9.5 (0.37)	396 (15.59)	9 (0.35)	9 (0.35)
LSLV1850H100-4								
LSLV1850H100-4								
LSLV1850H100-4								
LSLV1850H100-4								
LSLV1850H100-4								
LSLV1850H100-4								
LSLV1850H100-4								
LSLV1850H100-4								
LSLV1850H100-4								

IP00 Type

Model	W1	W2	H1	H2	H3	D	A	B
LSLV2200H100-4	426 (16.77)	320 (12.60)	922.3 (36.31)	895.5 (35.26)	15.5 (0.61)	440 (17.32)	11 (0.43)	11 (0.43)
LSLV2500H100-4								
LSLV3150H100-4	600 (23.62)	420 (16.54)	1000 (39.37)	972 (38.27)	15 (0.59)	500 (19.69)	14 (0.55)	14 (0.55)
LSLV350H100-4								
LSLV4000H100-4								
LSLV5000H100-4								
LSLV5000H100-4	776 (30.55)	500 (19.69)	1054 (41.50)	1021 (40.20)	20 (0.79)			

iS7

High Performance Drive



- 3Ø 200V 0.75kW~90kW
- 3Ø 400V 0.75kW~450kW

IP54

- 3Ø 200V 0.75~30kW
- 3Ø 400V 0.75~30kW

iS7, a High-performance and High-reliability Drive

iS7 is a high-performing standard drive that is applicable to any working environment.



Powerful Sensorless Vector Control

Sensorless vector algorithms developed with our accumulated technologies that demonstrate powerful control of low-speed torque and speed accuracy are built-in.



A Variety of Functions

V/F, V/F PG, slip compensation, sensorless vector, and sensed vector control are possible. LS satisfies any customer's needs through various functions such as torque control, droop control, KEB, Flying Start, and Easy Start.



Intended Use

- Warping / Beaming machine
- Laminating machine
- Drawing machine
- Tire line
- Elevator
- Construction lift
- Crane/Hoist
- Parking equipment
- Auto warehouse
- Press
- Washer/Dehydrator
- Compressor

Product Type & Model

SV 0008 iS7 - 2 N O F D W

LS Drive Starvert Series

Drive Capacity
0008: 0.75kW ~3750: 375kW

Series Name

Input Voltage
2: 3Ø 200~230V / 4: 3Ø 380~480V

Keypad
N: Non-Keypad / G: Graphic Keypad

UL Standard
O: Open / E: Enclosed UL Type 1 ^{Note 1} / P: Enclosed UL Type 12 ^{Note 2}

Filter
Blank: Non-Filter / F: Built-in EMC Filter

DC Reactor
Blank: Non-DC Reactor / D: Built-in DC Reactor / R: DB Resistor (Inner mounted) ^{Note 3}

Customized Product
W: Winder / S: Synchronous / T: Safety ^{Note 4} / V: Marine
Customization (W: Web control, S: Synchronization, V: Vessel E: High efficiency)

^{Note 1} For 0.75~75kW range, enclosed type 1 can be satisfied if conduit option installed.

^{Note 2} Enclosed UL type 1,2 is available from 0.75 to 22kW.

^{Note 3} Built-in DB resistor option is available only for web version product from 0.75kW to 3.7kW.
DB resistor of iS7 product is the option of WEB product.
Applicable capacity is from 0.75 to 375 kW of iS7 products.

^{Note 4} For 0.75~160kW, safety type products have built-in safety options. However, safety options should be purchased and applied to general products for 185~375kW products.



Main Functions

Features	Description	Benefits
Powerful Control Performance	Sensor-less vector control, sensored control, and auto tuning	Improved accuracy in speed and torque operation
Safety Card	2-channel STO (Safety Torque Off) 0.75~160kW Safety option built-in (185~375kW optional built-in)	Satisfied the safety standards and contacts with complete safety functions provided
Various Field Networks	Profibus-DP, Ethernet IP, Modbus TCP, CANopen, PROFINET, CC link, RAPIEnet, LonWorks, R-Net/F-Net communication network options	Possible to handle various field networks; convenient maintenance of options board; and easier mounting
EMC Filter	200V/400V 0.75~22kW capacity EMC filter built-in product options	Reduced electromagnetic noise; and additional space and expenses for parts unnecessary
DC Reactor	Capacity with built-in reactors ※ 200V 0.75~22kW ※ 400V 0.75~220kW	Minimized harmonics and power factor decline
Application-customized Functions	Web function (wire-drawing machine) S/W option; position and synchronization control option; and classification option	Flexible application for load equipment used in various industrial sectors

Control

Control Mode	V/F, V/F PG, Slip compensation, Sensorless, Sensored vector
Frequency Setting Resolution	Digital command: 0.01Hz / Analogue command: 0.06Hz (peak frequency: 60Hz)
Frequency Level	Digital command operation: 0.01% of the peak output frequency / Analogue command operation: 0.1% of the peak output frequency
V/F Pattern	Linear, square-law torque reduction, user V/F
Overload Capacity	CT (Heavy Duty) current rating: 150% 1min / VT (Normal Duty) current rating: 110% 1min
Torque Boost	Passive torque boost; auto torque boost

Operation

Operation Mode	Keypad / Terminal Block / Communication Network options	
Frequency Setting	Analogue method: 0 ~ 10 (V), -10 ~ 10 (V), 0 ~ 20 (mA) Digital method: Keypad	
Operation Function	PID control; up-down operation; 3-wire operation; DC braking; frequency limit; frequency jump; secondary function; slip compensation; reverse rotation prevention; auto restart; power switching; auto tuning; speed search (Flying Start); energy buffering operation; Power Braking; Flux Braking; leakage-reduced operation; MMC; Easy Start	
Input	NPN (Sink) / PNP (Source) Options	
	Multifunctional Terminal (8Points) P1 ~ P8 <small>Note 5)</small>	Function: Forward operation; backward operation; reset; external trip; emergency trip; jog operation; switching frequency – high, middle, low; acceleration and deceleration by stage – high, middle, low; DC braking at pause; second motor option; frequency increase; frequency decline; 3-wire operation; switching to the general operation during PID operation; switching to body operation during option operation; analogue command fixed frequency; acceleration or deceleration stop
Output	Multifunctional Open Collector Terminal	DC 26V 100mA or below
	Multifunctional Relay Terminal	Fault output and drive operation mode output (N.O., N.C.) AC 250V 1A or below, DC 30V 1A or below
	Analogue Output	0 ~ 10 Vdc (20mA or below): Frequency, current, voltage, DC voltage options

Note 5) According to the parameter setting of IN-65~72, various functions related to multifunctional terminal can be set.

iS7

High Performance Drive

200V Class (0.75~22kW)

SV□□□□iS7-2□			0008	0015	0022	0037	0055	0075	0110	0150	0185	0220
Applied Motor ^{Note 1)}	Heavy Duty (CT)	(HP)	1	2	3	5	7.5	10	15	20	25	30
		(kW)	0.75	1.5	2.2	3.7	5.5	7.5	11	15	18.5	22
	Normal Duty (VT)	(HP)	2	3	5	7.5	10	15	20	25	30	40
		(kW)	1.5	2.2	3.7	5.5	7.5	11	15	18.5	22	30
Output	Rated Capacity (kVA) ^{Note 2)}		1.9	3.0	4.5	6.1	9.1	12.2	17.5	22.9	28.2	33.5
	Rated Current (A) ^{Note 3)}	CT	5	8	12	16	24	32	46	60	74	88
		VT	8	12	16	24	32	46	60	74	88	124
	Rated Frequency (Hz)		0~400 (Hz) (Sensorless-1: 0~300Hz, Sensorless-2, Vector: 0~120Hz) ^{Note 4)}									
	Rated Voltage (V)		3Ø 200~230V ^{Note 5)}									
Input	Rated Voltage (V)		3Ø 200~230VAC (-15% ~ +10%)									
	Rated Frequency (Hz)		50~60 (Hz) (±5%)									
	Rated Current (A)	CT	4.3	6.9	11.2	14.9	22.1	28.6	44.3	55.9	70.8	85.3
		VT	6.8	10.6	14.9	21.3	28.6	41.2	54.7	69.7	82.9	116.1
Weight[kg], Non EMC&DCR			4.5			7.7			14		22.9	

200V Class (30~75kW)

SV□□□□iS7-2□			0300	0370	0450	0550	0750	-	-	-	-	-
Applied Motor ^{Note 1)}	Heavy Duty (CT)	(HP)	40	50	60	75	100	-	-	-	-	-
		(kW)	30	37	45	55	75	-	-	-	-	-
	Normal Duty (VT)	(HP)	50	60	75	100	125	-	-	-	-	-
		(kW)	37	45	55	75	90	-	-	-	-	-
Output	Rated Capacity (kVA) ^{Note 2)}		46	57	69	84	116	-	-	-	-	-
	Rated Current (A) ^{Note 3)}	CT	116	146	180	220	288	-	-	-	-	-
		VT	146	180	220	288	345	-	-	-	-	-
	Rated Frequency (Hz)		0~400 (Hz) (Sensorless-1: 0~300Hz, Sensorless-2, Vector: 0~120Hz) ^{Note 4)}									
	Rated Voltage (V)		3Ø 200~230V ^{Note 5)}									
Input	Rated Voltage (V)		3Ø 200~230VAC (-15% ~ +10%)									
	Rated Frequency (Hz)		50~60 (Hz) (±5%)									
	Rated Current (A)	CT	121	154	191	233	305	-	-	-	-	-
		VT	152	190	231	302	362	-	-	-	-	-
Weight[kg], Non EMC&DCR			29.5	44		72.5		-	-	-	-	-

400V Class (0.75~22kW)

SV□□□□iS7-4 □			0008	0015	0022	0037	0055	0075	0110	0150	0185	0220	
Applied Motor ^{Note 1)}	Heavy Duty (CT)	(HP)	1	2	3	5	7.5	10	15	20	25	30	
		(kW)	0.75	1.5	2.2	3.7	5.5	7.5	11	15	18.5	22	
	Normal Duty (VT)	(HP)	2	3	5	7.5	10	15	20	25	30	40	
		(kW)	1.5	2.2	3.7	5.5	7.5	11	15	18.5	22	30	
Output	Rated Capacity (kVA) ^{Note 2)}		1.9	3.0	4.5	6.1	9.1	12.2	18.3	22.9	29.7	34.3	
	Rated Current (A) ^{Note 3)}	CT	2.5	4	6	8	12	16	24	30	39	45	
		VT	4	6	8	12	16	24	30	39	45	61	
	Rated Frequency (Hz)		0~400 (Hz) (Sensorless-1: 0~300Hz, Sensorless-2, Vector: 0~120Hz) ^{Note 4)}										
	Rated Voltage (V)		3Ø 380~480V ^{Note 5)}										
Input	Rated Voltage (V)		3Ø 380~480VAC (-15%~+10%)										
	Rated Frequency (Hz)		50~60 (Hz) (±5%)										
	Rated Current (A)	CT	2.2	3.6	5.5	7.5	11.0	14.4	22.0	26.6	35.6	41.6	
		VT	3.7	5.7	7.7	11.1	14.7	21.9	26.4	35.5	41.1	55.7	
Weight[kg], Non EMC&DCR			4.5			7.7			14		19.7		20.1

^{Note 1)} The maximum applicable capacity when using a standard 4-pole electric motor is marked. (200V Class is based on 220V and 400V on 440V.)

^{Note 2)} When it comes to the rated capacity, the input capacity of 200V is based on 220V and that of 400V on 440V. The current rating is based on the CT current.

^{Note 3)} The output rated current is limited according to carrier frequency (CON-04) setting.

^{Note 4)} When the control mode (DRV-09 Control Mode) is No.3 Sensorless-1 and No.4 Sensorless-2, the peak frequency of Sensorless-1 can be set up to 300Hz and that of Sensorless-2 up to 120Hz.

^{Note 5)} The peak output voltage does not exceed the source voltage. The output voltage can be set within the source (power supply) voltage.

♦The performance of NON DCR products is guaranteed only for CT (Heavy Duty) load.

400V Class (30~375kW)

SV□□□□iS7-4□			0300	0370	0450	0550	0750	0900	1100	1320	1600	1850	2200	2800	3150	3750		
Applied Motor ^{Note 1)}	Heavy Duty (CT)	(HP)	40	50	60	75	100	125	150	200	250	300	350	400	500	600		
		(kW)	30	37	45	55	75	90	110	132	160	185	220	280	315	375		
	Normal Duty (VT)	(HP)	50	60	75	100	125	150	200	250	300	350	400	500	600	700		
		(kW)	37	45	55	75	90	110	132	160	185	220	280	315	375	450		
Output	Rated Capacity (kVA) ^{Note 2)}		46	57	69	84	116	139	170	201	248	286	329	416	467	557		
	Rated Current (A) ^{Note 3)}	CT	61	75	91	110	152	183	223	264	325	370	432	547	613	731		
		VT	75	91	110	152	183	223	264	325	370	432	547	613	731	877		
	Rated Frequency (Hz)		0~400 (Hz) (Sensorless-1: 0~300Hz, Sensorless-2, Vector: 0~120Hz) ^{Note 4)}															
Rated Voltage (V)		3Ø 380~480V ^{Note 5)}																
Input	Rated Voltage (V)		3Ø 380~480VAC (-15%, +10%)															
	Rated Frequency (Hz)		50~60 (Hz) (±5%)															
	Rated Current (A)	CT	55.5	67.9	82.4	102.6	143.4	174.7	213.5	255.6	316.3	404	466	605	674	798		
		VT	67.5	81.7	101.8	143.6	173.4	212.9	254.2	315.3	359.3	463	590	673	796	948		
Weight[kg], Non EMC&DCR			28			45			101*		114*		200*		252		352	

Note 1) The maximum applicable capacity when using a standard 4-pole electric motor is marked. (200V Class is based on 220V and 400V on 440V.)

Note 2) When it comes to the rated capacity, the input capacity of 200V is based on 220V and that of 400V on 440V. The current rating is based on the CT current.

Note 3) The output rated current is limited according to E carrier frequency (CON-04) setting.

Note 4) When the control mode (DRV-09 Control Mode) is No.3 Sensorless-1 and No.4 Sensorless-2, the peak frequency of Sensorless-1 can be set up to 300Hz and that of Sensorless-2 up to 120Hz.

Note 5) The peak output voltage does not exceed the source voltage. The output voltage can be set within the source (power supply) voltage.

◆ The performance of NON DCR products is guaranteed only for CT (Heavy Duty) load.

iS7

High Performance Drive

Product Dimension

(IP20/IP00)

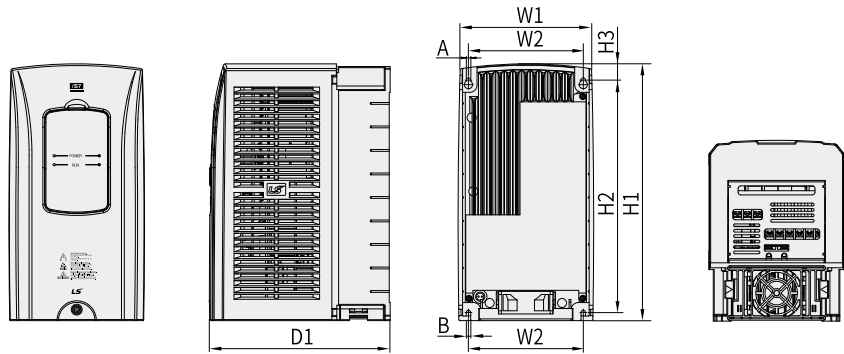

Unit: mm (inches)

Model	W1	W2	H1	H2	H3	D1	A	B
SV0008~0037iS7-2/4	150 (5.90)	127 (5.00)	284 (11.18)	257 (10.11)	18 (0.70)	200 (7.87)	5 (0.19)	5 (0.19)
SV0055~0075iS7-2/4	200 (7.87)	176 (6.92)	355 (13.97)	327 (12.87)	19 (0.74)	225 (8.85)		
SV0110~0150iS7-2/4	250 (9.84)	214.6 (8.44)	385 (15.15)	355 (13.97)	23.6 (0.92)	284 (11.18)	6.5 (0.25)	6.5 (0.25)
SV0185~0220iS7-2/4	280 (11.02)	243.5 (9.58)	461.6 (18.17)	445 (17.51)	10.1 (0.39)	298 (11.73)		

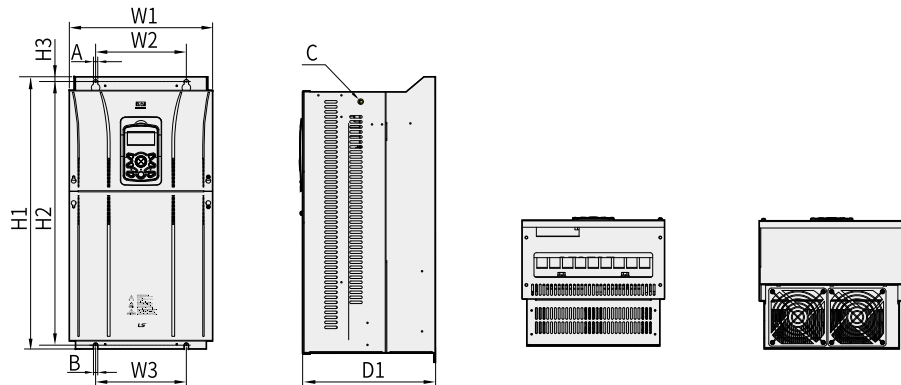

Unit: mm (inches)

Model	W1	W2/W3	H1	H2	H3	D1	A	B	C
SV0300iS7-2	300 (11.81)	190 (7.48)	570 (22.44)	552 (21.73)	10 (0.39)	265.2 (10.44)	10 (0.39)	9 (0.35)	M8
SV0370~0450iS7-2	370 (14.56)	270 (10.63)	630 (24.8)	609 (23.97)	11 (0.43)	281.2 (11.07)			M10
SV0550~0750iS7-2	465 (18.3)	381 (15.0)	750 (29.52)	723.5 (28.48)	15.5 (0.61)	355.6 (14.0)	11 (0.43)	11 (0.43)	M16

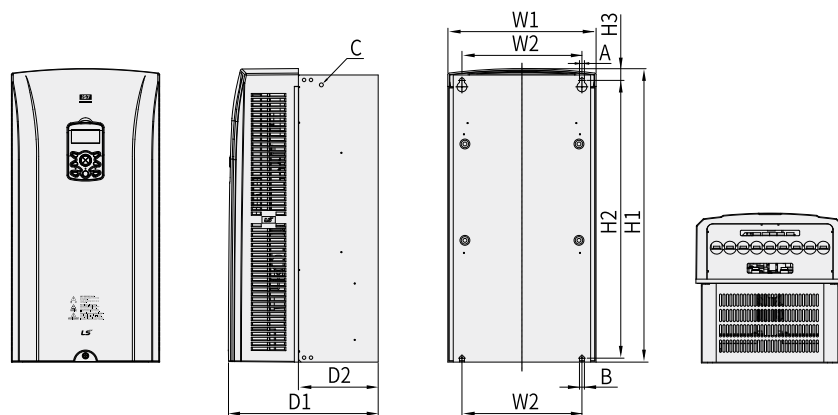

Unit: mm (inches)

Model	W1	W2	H1	H2	H3	D1	D2	A	B	C
SV0300~0450iS7-4	300.1 (11.81)	242.8 (9.55)	594.1 (23.38)	562 (22.12)	24.1 (0.94)	DCR type		10 (0.39)	10 (0.39)	M8
						302.7(11.92)	161(6.33)			
SV0550~0750iS7-4	370.1 (14.57)	312.8 (12.31)	663.5 (26.12)	631.4 (24.85)	24.1 (0.94)	DCR type		10 (0.39)	10 (0.39)	M8
						373.3(14.69)	211.5(8.32)			

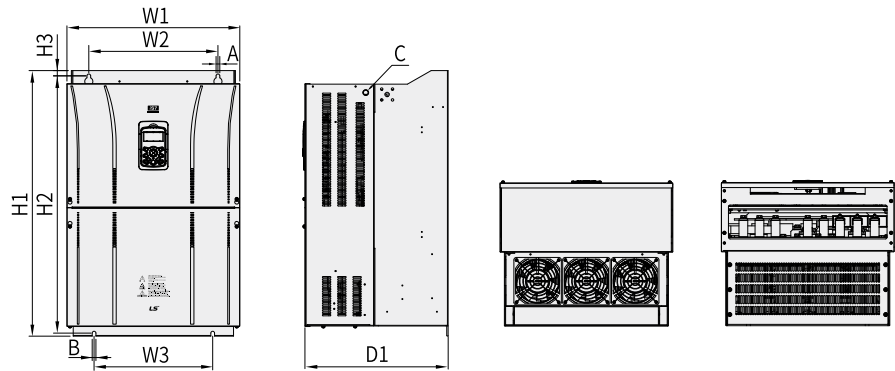

Unit: mm (inches)

Model	W1	W2	W3	H1	H2	H3	D1	A	B	C
SV0900~1100iS7-4	510 (20.07)	381 (15.0)	350 (13.77)	783.5 (30.84)	759 (29.88)	15.5 (0.61)	422.6 (16.63)	11 (0.43)	11 (0.43)	M16
SV1320~1600iS7-4	510 (20.07)	381 (15.0)	350 (13.77)	861 (33.89)	836.5 (32.93)	15.5 (0.61)	422.6 (16.63)			
SV1850~2200iS7-4	690 (27.16)	581 (22.87)	528 (20.79)	1078 (42.44)	1043.5 (41.08)	25.5 (1.00)	449.6 (17.70)	14 (0.55)	15 (0.59)	M20
SV2800iS7-4	772 (30.39)	500 (19.69)	500 (19.69)	1140.5 (44.90)	1110 (43.70)	15 (0.59)	442 (17.40)	13 (0.51)	13 (0.51)	M16
SV3150~3750iS7-4	922 (36.30)	580 (22.83)	580 (22.83)	1302.5 (51.28)	1271.5 (50.06)	15.5 (0.61)	495 (19.49)	14 (0.55)	14 (0.55)	

Product Dimension

(IP54)

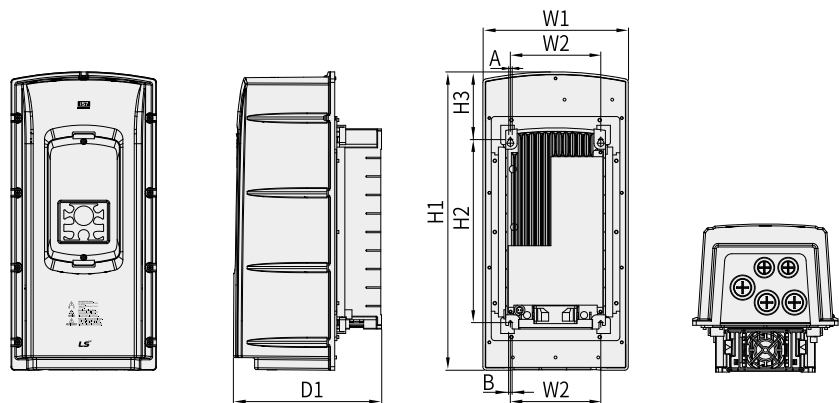

Unit: mm (inches)

Model	W1	W2	H1	H2	H3	D1	A	B
SV0008~0037iS7-2/4	204.2 (8.04)	127 (5.00)	419 (16.49)	257 (10.12)	95.1 (3.74)	208 (8.18)	5 (0.19)	5 (0.19)
SV0055~0075iS7-2/4	254 (10.00)	176 (6.92)	460.6 (18.13)	327 (12.87)	88.1 (3.46)	232.3 (9.14)		
SV0110~0150iS7-2/4	313.1 (12.32)	214.6 (8.44)	590.8 (23.25)	355 (13.97)	101.7 (4.00)	294.4 (11.59)	6.5 (0.25)	6.5 (0.25)
SV0185~0220iS7-2/4	343.2 (13.51)	243.5 (9.58)	750.8 (29.55)	445 (17.51)	91.6 (3.60)	315.5 (12.42)		

iV5

Vector Drive



- 3Ø 200V 2.2~37kW
- 3Ø 400V 2.2~800kW
- DC input type 400V 5.5~500kW



200/400VAC(Press Type)
Eertification up to 220kW



ISO9001 ISO14001



iV5, an Optimal Drive Solution for High-performance System

It is a specialized drive for continuous line, crane system and elevator system control based on powerful functions and performance.



Installed With High-performance Control Functions

It is equipped with high-performing control functions, including high-performance speed/torque control; SIN/COS; super-precision control based on Endat encoder; static auto tuning; Draw/Droop/ Process PID control; and built-in brake control.



User-centered Interface

It supports systems and efficient management with user-centered keypads and terminal blocks, communication networks and Drive View.



Intended Use

- Metal (winder, hoist)
- Textile (threading, spinning)
- Plastic, rubber (winder)
- Food and beverage (Packing, Cutting and labeling machines)
- Paper, pulp (winder, printer and slitter)
- Coal mine (crane, hoist)
- Crane, hoist

Product Type & Model

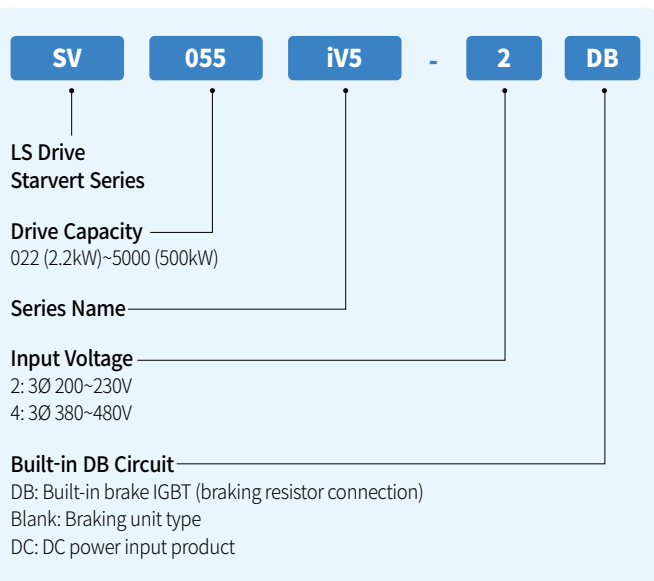

Main Function

Features	Description	Benefits
Improved System-centered Functions	Installed with advanced functions, including high-performance speed/torque control based on 200% instantaneous torque control; position/synchronization control; and brake control	An optimal solution for vertical load application, including continuous lines, cranes and elevators
Exclusive for Elevators	High-accuracy position control and exclusive machine room-less drive	Safe and efficient elevator operation guaranteed
Equipped With Various Options	Synchronization option, encoder option, scalable I/O, I/O option for elevators and etc.	Widely applied to various vector applications
Various Interfaces	RS485, Modbus-RTU, Device Net, Profibus-DP and CC-Link communication network options	Connectable to commonly used field networks; simple maintenance of option cards; and easier mounting

Control

Control Mode	Sensored vector, Sensorless vector	
Speed Control Level	Analogue setting: $\pm 0.1\%$ of the maximum speed (1800rpm) ($25 \pm 10^\circ\text{C}$) Digital setting: $\pm 0.1\%$ of the maximum speed (1800rpm) ($0 \sim 40^\circ\text{C}$)	
Speed Setting Resolution	Analogue setting: $\pm 0.1\%$ of the maximum speed / Digital setting: 0.1rpm	
Speed Control Response Speed	50Hz	
Torque Control Level	$\pm 3\%$	
Overload Capacity	Continuous (CT): 150% / 1min	
Acceleration/ Deceleration	Time Setting	0.00~6000.0
	Combination	4 types of acceleration/deceleration time options
	Pattern	Linear, S-curve

Brake

Braking Mode	Discharge-resistant braking
Braking Torque	150%
Braking Resistance	A separate braking resistor should be installed outside

200V Class (AC Power Input Type)

SV□□□ iV5-2		022	037	055	075	110	150	185	220	300	370
Applied Motor <small>Note 1)</small>	(HP)	3	5	7.5	10	15	20	25	30	40	50
	(kW)	2.2	3.7	5.5	7.5	11	15	18.5	22	30	37
Output	Capacity (kVA) <small>Note 2)</small>	4.5	6.1	9.1	12.2	17.5	22.5	28.2	33.1	46	55
	Rated Current (A)	12	16	24	32	46	59	74	88	122	146
	Rated Speed (RPM)	0~3600 (rpm)									
	Rated Voltage (V)	200~230V <small>Note 3)</small>									
Input	Rated Voltage (V)	3Ø 200~230V (-10%~+10%)									
	Rated Frequency (Hz)	50~60Hz (±5%)									
Drive Weight (kg)		6	6	7.7	7.7	13.7	13.7	20.3	20.3	42	42

400V Class (AC Power Input Type)

SV□□□ iV5-4		022	037	055	075	110	150	185	220	300	370
Applied Motor <small>Note 1)</small>	(HP)	3	5	7.5	10	15	20	25	30	40	50
	(kW)	2.2	3.7	5.5	7.5	11	15	18.5	22	30	37
Output	Capacity (kVA) <small>Note 2)</small>	4.5	6.1	9.1	12.2	18.3	22.9	29.7	34.3	46	57
	Rated Current (A)	6	8	12	16	24	30	39	45	61	75
	Rated Speed (RPM)	0~3600 (rpm)									
	Rated Voltage (V)	380~480V <small>Note 3)</small>									
Input	Rated Voltage (V)	3Ø 380~480V (-10%~+10%) <small>Note 4)</small>									
	Rated Frequency (Hz)	50~60Hz (±5%)									
Drive Weight (kg)		6	6	7.7	7.7	13.7	13.7	20.3	20.3	42	42

SV□□□ iV5-4		450	550	750	900	1100	1320	1600	2200	2800	3150	3750	5000	8000	
Applied Motor <small>Note 1)</small>	(HP)	60	75	100	120	150	175	215	300	373	420	500	666	1067	
	(kW)	45	55	75	90	110	132	160	220	280	315	375	500	800	
Output	Capacity (kVA) <small>Note 2)</small>	70	85	116	140	170	200	250	329	416	468	557	732	1105	
	Rated Current (A)	91	110	152	183	223	264	325	432	546	614	731	960	1384	
	Rated Speed (RPM)	0~3600 (rpm)													
	Rated Voltage (V)	380~480V <small>Note 3)</small>													
Input	Rated Voltage (V)	3Ø 380~480V (-10%~+10%) <small>Note 4)</small>													
	Rated Frequency (Hz)	50~60Hz (±5%)													
Drive Weight (kg)		63	63	68	98	98	122	122	175	243	380	380	476	1300	

Note 1) The maximum allowable capacity is marked when using a standard 4-pole motor. (200V Class is based on 220V and 400V Class on 440V.)

Note 2) The rated capacity ($=\sqrt{3} \times V \times I$) is 220V for 200V Class and 440V for 400V Class.

Note 3) The maximum output voltage does not exceed the source voltage.

Note 4) When the input voltage is 480V or above, 10% derating of the rated current should be performed

400V Class (DC Power Input Type)

SV□□□ iV5-4(DC)		055	075	110	150	185	220	300	370	450	550
Applied Motor <small>Note 1)</small>	(HP)	7.5	10	15	20	25	30	40	50	60	75
	(kW)	5.5	7.5	11	15	18.5	22	30	37	45	55
Output	Capacity (kVA) <small>Note 2)</small>	9.1	12.2	18.3	22.9	29.7	34.3	46	57	70	85
	Rated Current (A)	12	16	24	30	39	45	61	75	91	110
	Rated Speed (RPM)	0~3600 (rpm)									
	Rated Voltage (V)	380~480V <small>Note 3)</small>									
Input Rated Voltage	DC 540~680V (+10%) <small>Note 4)</small>										
Drive Weight (kg)	12	12	24	24.5	25	25	38.5	38.5	50	50	

SV□□□ iV5-4(DC)		750	900	1100	1320	1600	2200	2800	3150	3750	5000
Applied Motor <small>Note 1)</small>	(HP)	100	120	150	175	215	300	373	420	500	666
	(kW)	75	90	110	132	160	220	280	315	375	500
Output	Capacity (kVA) <small>Note 2)</small>	116	140	170	200	250	329	416	468	557	732
	Rated Current (A)	152	183	223	264	325	432	546	614	731	960
	Rated Speed (RPM)	0~3600 (rpm)									
	Rated Voltage (V)	380~480V <small>Note 3)</small>									
Input Rated Voltage	DC 540~680V (+10%) <small>Note 4)</small>										
Drive Weight (kg)	55	79	79	98.5	98.5	154.5	206	343	343	466	

MRL

SV□□□ iV5-4(MRL)		075	110	150	220
Applied Motor <small>Note 1)</small>	(HP)	10	15	20	30
	(kW)	7.5	11	15	22
Output	Capacity (kVA) <small>Note 2)</small>	13.7	20.6	27.5	39.6
	Rated Current (A)	18	27	36	52
	Rated Speed (RPM)	0~200 (rpm)			
	Rated Voltage (V)	380~480V <small>Note 3)</small>			
Input	Rated Voltage (V)	3Ø 380~480V (-10%~+10%) <small>Note 5)</small>			
	Rated Frequency (Hz)	50~60Hz (±5%)			
Drive Weight (kg)	14	14	18.7	19	

Note 1) The maximum allowable capacity is marked when using a standard 4-pole motor. (200V Class is based on 220V and 400V Class on 440V.)

Note 2) The rated capacity ($=\sqrt{3} \cdot V \cdot I$) is 220V for 200V Class and 440V for 400V Class.

Note 3) The maximum output voltage does not exceed the source voltage.

Note 4) When the input voltage is 680VDC or above, 10% derating of the rated current should be performed.

Note 5) When the input voltage is 507~528V, 10% derating of the rated current should be performed.

Product Dimension

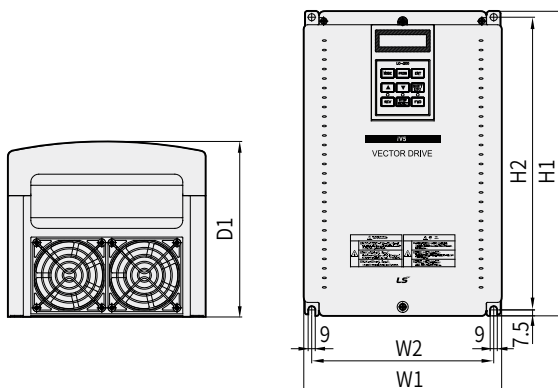

Unit: mm (inches)

Model	W1	W2	H1	H2	D1
SV022iV5-2/4DB (MD) SV037iV5-2/4DB (MD)	200 (7.87)	180 (7.08)	284 (11.18)	269 (10.59)	207 (8.14)
SV055iV5-2/4DB (MD) SV075iV5-2/4DB (MD)			355 (13.97)	340 (13.38)	202 (7.95)
SV110iV5-2/4DB (MD) SV150iV5-2/4DB (MD)	250 (9.84)	230 (9.05)	385 (15.15)	370 (14.56)	221 (8.70)
SV185iV5-2/4DB (MD) SV220iV5-2/4DB (MD)	340 (13.38)	284 (11.18)	460 (18.11)	445 (17.51)	254 (10.00)

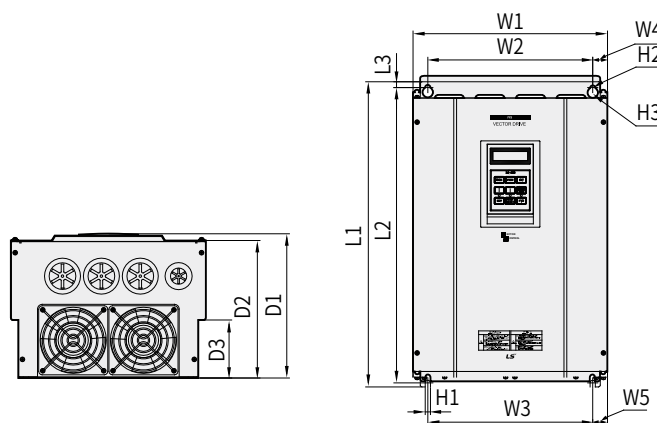

Unit: mm (inches)

Model	W1	W2	W3	W4	W5	L1	L2	L3	D1	D2	D3	H1	H2	H3
SV055iV5-2/4DB SV075iV5-2/4DB	234.4 (9.22)	180 (7.08)		27.2 (1.07)		406.2 (15.99)	391.2 (15.40)	7.5 (0.29)	221.1 (8.70)	209.5 (8.24)	75 (2.95)	6 (0.23)	Φ6 (Φ0.23)	Φ12 (Φ0.47)
SV110 iV5-2/4DB SV150iV5-2/4DB							25.5 (1.00)	526 (20.70)	509 (20.03)	10 (0.39)	248.6 (9.78)	237 (9.33)	100 (3.93)	7 (0.27)
SV185iV5-2/4DB SV220iV5-2/4DB	335 (13.18)	284 (11.18)												

* The dimension of DC Input Type products is same as that of AC Input Type ones.

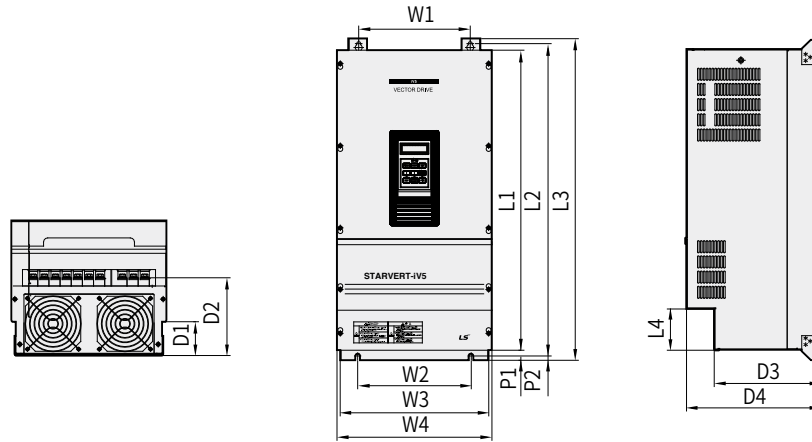

Unit: mm (inches)

Model	W1	W2	W3	W4	L1	L2	L3	D1	D2	D3	D4	P1	P2
SV300iV5-2/4	270		319.2	350	635	660	680	120	197	256.6	308.2	16.9	8
SV370iV5-2/4	(10.62)		(12.56)	(13.77)	(25.00)	(25.98)	(26.77)	(4.72)	(7.75)	(10.10)	(12.13)	(0.66)	(0.31)
SV450iV5-4	275		359.6	375	730.6	758.5	780	82.3	189.3	259	326	24.5	10.5
SV550iV5-4	(10.82)		(14.15)	(14.76)	(28.76)	(29.86)	(30.70)	(3.24)	(7.45)	(10.19)	(12.83)	(0.96)	(0.41)
SV750iV5-4													

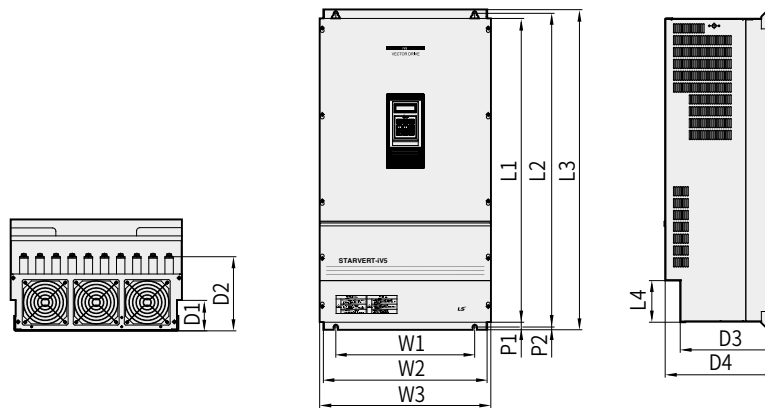

Unit: mm (inches)

Model	W1	W2	W3	L1	L2	L3	D1	D2	D3	D4	P1	P2
SV900iV5-4				729	760	780	83.2	234.6	286.2	335		
SV1100iV5-4	430	507	530	(28.70)	(29.92)	(30.70)	(3.27)	(9.23)	(11.26)	(13.18)	23.5	8.5
SV1320iV5-4	(16.92)	(19.96)	(20.86)	949	980	1000	95.2	231.6	298	345	(0.92)	(0.33)
SV1600iV5-4				(37.36)	(38.58)	(39.37)	(3.74)	(9.11)	(11.73)	(13.58)		

* The dimension of DC Input Type products is same as that of AC Input Type ones.

Product Dimension

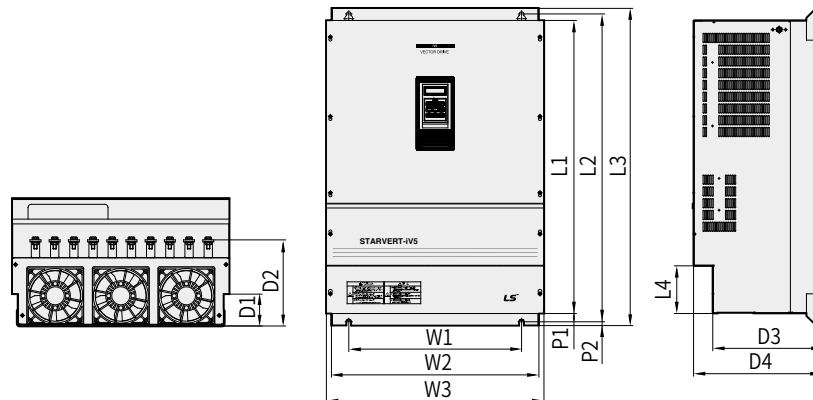

Unit: mm (inches)

Model	W1	W2	W3	L1	L2	L3	L4	D1	D2	D3	D4	P1	P2
SV2200iV5-4	540 (21.25)	649 (25.55)	680 (26.77)	922 (36.29)	968.5 (38.12)	998 (39.29)	150 (5.90)	100.2 (3.94)	271 (10.66)	343 (13.50)	403 (15.86)	38 (1.49)	12 (0.47)

* The dimension of DC Input Type products is same as that of AC Input Type ones.

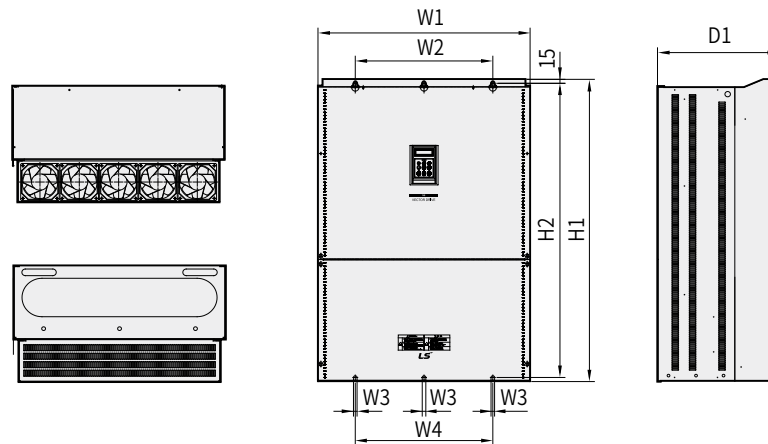

Unit: mm (inches)

Model	W1	W2	W3	W4	H1	H2	D1
SV2800iV5-4	772 (30.39)	500 (19.68)	13 (0.51)	500 (19.68)	1140.5 (44.90)	1110 (43.70)	442 (17.40)
SV3150iV5-4	922 (36.29)	580 (22.83)	14 (0.55)	580 (22.83)	1302.5 (51.27)	1271.5 (50.05)	495 (19.48)
SV3750iV5-4							

* The dimension of DC Input Type products is same as that of AC Input Type ones.

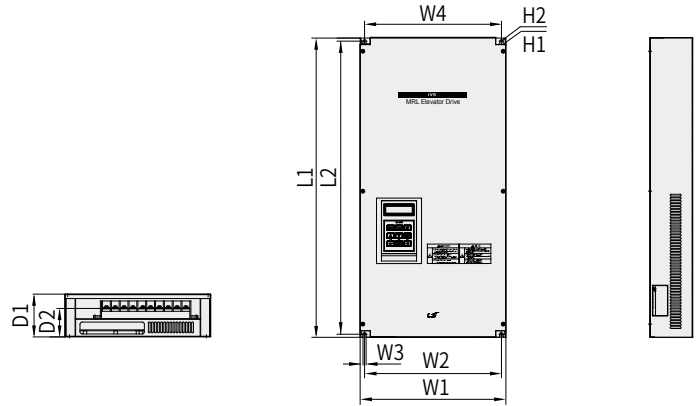

Unit: mm (inches)

Model	W1	W2	W3	W4	L1	L2	D1	D2	H1	H2
MRL 075-4	330 (12.99)	310 (12.20)	7 (0.27)	310 (12.20)	680 (26.77)	666 (26.22)	97.2 (3.82)	64.7 (2.54)	14 (0.55)	7 (0.27)
MRL 110-4										
MRL 150-4	375 (14.76)	355 (13.97)		355 (13.97)	700 (27.55)	686 (27.00)	108.5 (4.27)	75.7		
MRL 220-4							139.2 (5.48)	101.3		

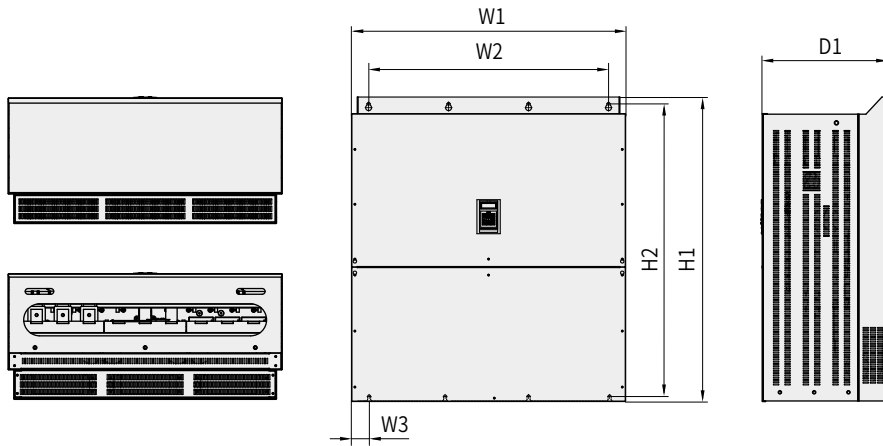

Unit: mm (inches)

Model	W1	W2	W3	H1	H2	D1
SV5000iV5-4	1200 (47.24)	1050 (41.33)	75 (2.95)	1330 (52.36)	1280 (50.39)	550 (21.65)

Guide to LS Drive Options

The table below describes a list of options for various LS drives. Please contact LS for further details on our drive options.

Series	Option Name
M100	M100 remote keypad
	Remote cable (1m, 2m, 3m, 5m)
iE5	Modbus RTU
iG5A	iG5A remoted keypad
	Remoted cable (2m, 3m, 5m)
G100	2 Port Ethernet/IP (Modbus TCP)
	Profibus-DP
	CANopen
	G100 remote keypad *
	Remote cable (1m, 2m, 3m, 5m)
S100	Modbus TCP
	PROFINet
	EtherCAT
	EtherNet/IP
	Profibus-DP
	CANopen
	Scalable I/O
	S100 LCD keypad
	S100 remote keypad (LED)
	Remote cable (1m, 2m, 3m, 5m)
H100	Lonworks
	H100 remote keypad
	Remote cable (1m, 2m, 3m, 5m)
iS7	EtherNet IP/Modbus TCP(1Port)
	EtherNet IP/Modbus TCP(2Port)
	PROFINET
	CC-Link IE
	RAPIEnet
	RAPIEnet+ (2port) (Ethernet IP, Modbus TCP, RAPIEnet)
	DeviceNet
	Profibus-DP
	CANopen
	CC-Link
	Modbus RTU
	Fnet, Rnet
	Lonworks
	PLC
	Extention I/O
	Safety
	Synchronous control
	Position control
	Binary Input
	Encoder(5/12/15V)
24V Encoder	
LCD Keypad	
Remote cable(2m, 3m)	

* G100/M100 remote keypads are compatible.

Series	Option Name
iV5	RS-485
	Modbus RTU
	DeviceNet
	Profibus-DP
	CC-Link
	Synchronization
	EL I / O
	SIN / COS + Endat
	Scalable I / O
	24V Encoder
Common	Parameter Copy Unit
	Smart Copier