

# Product data sheet

Specifications



## Variable speed drive, Altivar Process ATV900, ATV930, 55 kW, 400/480 V, with braking unit, IP21

ATV930D55N4

**Product availability : Stock - Normally stocked in distribution facility**

**Price\* : 9,567.60 USD**

### Main

|   |  |
|---|--|
| <b>Range of Product</b>                   | Altivar Process ATV900   |
| <b>Device Application</b>                 | Industrial Application   |
| <b>Product or Component Type</b>          | Variable speed drive   |
| <b>Product destination</b>                | Asynchronous motors<br>Synchronous motors  |
| <b>Product Specific Application</b>       | Process for industrial   |
| <b>Variant</b>                            | With braking chopper<br>Standard version   |
| <b>Phase</b>                              | 3 phase  |
| <b>Mounting Mode</b>                      | Wall mount   |
| <b>Communication port protocol</b>        | EtherNet/IP<br>Modbus TCP<br>Modbus serial   |
| <b>[Us] rated supply voltage</b>          | 380...480 V - 15...10 %  |
| <b>Motor power kW</b>                     | 55.0 kW normal duty<br>45.0 kW heavy duty  |
| <b>Maximum Horse Power Rating</b>         | 75.0 hp normal duty<br>60.0 hp heavy duty  |
| <b>Continuous output current</b>          | 106 A 2.5 kHz normal duty<br>88 A 2.5 kHz heavy duty   |
| <b>EMC filter</b>                         | Integrated<br>With EMC plate option  |
| <b>IP degree of protection</b>            | IP21   |
| <b>Degree of protection</b>               | UL type 1  |
| <b>Option module</b>                      | Slot A communication module Profibus DP V1<br>Slot A communication module PROFINET<br>Slot A communication module DeviceNet<br>Slot A communication module EtherCAT<br>Slot A communication module CANopen daisy chain RJ45<br>Slot A communication module CANopen SUB-D 9<br>Slot A communication module CANopen screw terminals<br>Slot A/slot B/slot C digital and analog I/O extension module<br>Slot A/slot B/slot C output relay extension module<br>Slot B 5/12 V digital encoder interface module<br>Slot B analog encoder interface module<br>Slot B resolver encoder interface module<br>communication module Ethernet Powerlink |
| <b>Discrete input logic</b>               | 16 preset speeds   |
| <b>Asynchronous motor control profile</b> | Constant torque standard<br>Optimized torque mode  |

\* Price is "List Price" and may be subject to a trade discount – check with your local distributor or retailer for actual price.

|  |  |
|--|--|
|  | Variable torque standard   |
| <b>Synchronous motor control profile</b> | Permanent magnet motor<br>Synchronous reluctance motor   |
| <b>Maximum output frequency</b>          | 599 Hz   |
| <b>Switching frequency</b>               | 1...8 kHz adjustable<br>2.5...8 kHz with derating factor   |
| <b>Nominal switching frequency</b>       | 2.5 kHz  |
| <b>Line current</b>                      | 97.2 A 380 V normal duty)<br>81.4 A 380 V heavy duty)<br>84.2 A 480 V normal duty)<br>71.8 A 480 V heavy duty)   |
| <b>Apparent power</b>                    | 70 kVA 480 V normal duty)<br>59.7 kVA 480 V heavy duty)  |
| <b>Maximum transient current</b>         | 127.2 A 60 s normal duty)<br>132 A 60 s heavy duty)  |
| <b>Network Frequency</b>                 | 50-60 Hz   |
| <b>Prospective line Isc</b>              | 50 kA  |
| <b>Complementary</b>                     |  |
| <b>Discrete input number</b>             | 10   |
| <b>Discrete input type</b>               | DI1...DI8 programmable, 24 V DC <= 30 V)3.5 kOhm<br>DI7, DI8 programmable as pulse input 0...30 kHz, 24 V DC <= 30 V)<br>STOA, STOB safe torque off, 24 V DC <= 30 V)> 2.2 kOhm  |
| <b>Discrete output number</b>            | 2  |
| <b>Discrete output type</b>              | Logic output DQ+ 0...1 kHz <= 30 V DC 100 mA<br>Programmable as pulse output DQ+ 0...30 kHz <= 30 V DC 20 mA<br>Logic output DQ- 0...1 kHz <= 30 V DC 100 mA   |
| <b>Analogue input number</b>             | 3  |
| <b>Analogue input type</b>               | AI1, AI2, AI3 software-configurable voltage 0...10 V DC 30 kOhm 12 bits<br>AI1, AI2, AI3 software-configurable current 0...20 mA/4...20 mA 250 Ohm 12 bits   |
| <b>Analogue output number</b>            | 2  |
| <b>Analogue output type</b>              | Software-configurable voltage AQ1, AQ2 0...10 V DC 470 Ohm 10 bits<br>Software-configurable current AQ1, AQ2 0...20 mA 500 Ohm 10 bits   |
| <b>Relay output number</b>               | 3  |
| <b>Relay output type</b>                 | Configurable relay logic R1 fault relay NO/NC 100000 cycles<br>Configurable relay logic R2 sequence relay NO 1000000 cycles<br>Configurable relay logic R3 sequence relay NO 1000000 cycles  |
| <b>Maximum switching current</b>         | Relay output R1 resistive, cos phi = 1 3 A 250 V AC<br>Relay output R1 resistive, cos phi = 1 3 A 30 V DC<br>Relay output R1 inductive, cos phi = 0.4 7 ms 2 A 250 V AC<br>Relay output R1 inductive, cos phi = 0.4 7 ms 2 A 30 V DC<br>Relay output R2, R3 resistive, cos phi = 1 5 A 250 V AC<br>Relay output R2, R3 resistive, cos phi = 1 5 A 30 V DC<br>Relay output R2, R3 inductive, cos phi = 0.4 7 ms 2 A 250 V AC<br>Relay output R2, R3 inductive, cos phi = 0.4 7 ms 2 A 30 V DC |
| <b>Minimum switching current</b>         | Relay output R1, R2, R3 5 mA 24 V DC   |
| <b>Physical interface</b>                | Ethernet<br>2-wire RS 485  |
| <b>Connector Type</b>                    | 2 RJ45<br>1 RJ45   |
| <b>Method of access</b>                  | Slave Modbus TCP   |
| <b>Transmission Rate</b>                 | 10, 100 Mbits<br>4.8 kbps<br>9600 bit/s<br>19200 bit/s   |
| <b>Transmission frame</b>                | RTU  |
| <b>Number of addresses</b>               | 1...247  |
| <b>Data format</b>                       | 8 bits, configurable odd, even or no parity  |

|  |  |
|--|--|
| Type of polarization                                 | No impedance   |
| 4 quadrant operation possible                        | True   |
| Acceleration and deceleration ramps                  | Linear adjustable separately from 0.01...9999 s  |
| Motor slip compensation                              | Automatic whatever the load<br>Not available in permanent magnet motor law<br>Can be suppressed<br>Adjustable  |
| Braking to standstill                                | By DC injection  |
| Brake chopper integrated                             | True   |
| Maximum Input Current per Phase                      | 97.2 A   |
| Maximum output voltage                               | 480.0 V  |
| Relative symmetric network frequency tolerance       | 5 %  |
| Base load current at high overload                   | 88.0 A   |
| Base load current at low overload                    | 106.0 A  |
| Power dissipation in W                               | Natural convection 131 W 380 V 2.5 kHz<br>Forced convection 917 W 380 V 2.5 kHz  |
| With safety function Safely Limited Speed (SLS)      | True   |
| With safety function Safe brake management (SBC/SBT) | True   |
| With safety function Safe Operating Stop (SOS)       | False  |
| With safety function Safe Position (SP)              | False  |
| With safety function Safe programmable logic         | False  |
| With safety function Safe Speed Monitor (SSM)        | False  |
| With safety function Safe Stop 1 (SS1)               | True   |
| With sft fct Safe Stop 2 (SS2)                       | False  |
| With safety function Safe torque off (STO)           | True   |
| With safety function Safely Limited Position (SLP)   | False  |
| With safety function Safe Direction (SDI)            | False  |
| Protection type                                      | Thermal protection motor<br>Safe torque off motor<br>Motor phase break motor<br>Thermal protection drive<br>Safe torque off drive<br>Overheating drive<br>Overcurrent between output phases and earth drive<br>Overload of output voltage drive<br>Short-circuit protection drive<br>Motor phase break drive<br>Overvoltages on the DC bus drive<br>Line supply overvoltage drive<br>Line supply undervoltage drive<br>Line supply phase loss drive<br>Overspeed drive<br>Break on the control circuit drive |
| Quantity per Set                                     | 1  |
| Width  | 11.42 in (290 mm)  |

|                                      |  |
|--------------------------------------|--|
| <b>Height</b>                        | 36.30 in (922 mm)  |
| <b>Depth</b>                         | 12.81 in (325.5 mm)  |
| <b>Net Weight</b>                    | 126.77 lb(US) (57.5 kg)  |
| <b>Electrical connection</b>         | Control screw terminal 0.5...1.5 mm <sup>2</sup> AWG 20...AWG 16<br>Line side screw terminal 70...120 mm <sup>2</sup> AWG 1/0...250 kcmil<br>Motor screw terminal 70...120 mm <sup>2</sup> AWG 1/0...250 kcmil<br>DC bus screw terminal 70...120 mm <sup>2</sup> AWG 1/0...250 kcmil<br><br>10/100 Mbit/s Ethernet IP/Modbus TCP<br>4.8, 9.6, 19.2, 38.4 kbit/s Modbus serial        |
| <b>Exchange mode</b>                 | Half duplex, full duplex, autonegotiation Ethernet IP/Modbus TCP<br><br>8 bits, configurable odd, even or no parity Modbus serial<br><br>No impedance Modbus serial<br><br>1...247 Modbus serial   |
| <b>Supply</b>                        | External supply for digital inputs 24 V DC 19...30 V), <1.25 mA overload and short-circuit protection<br>Internal supply for reference potentiometer (1 to 10 kOhm) 10.5 V DC +/- 5 %, <10 mA overload and short-circuit protection<br>Internal supply for digital inputs and STO 24 V DC 21...27 V), <200 mA overload and short-circuit protection                                  |
| <b>Local signalling</b>              | Local diagnostic 3 LED mono/dual colour)<br>Embedded communication status 5 LED dual colour)<br>Communication module status 2 LED dual colour)<br>Presence of voltage 1 LED red)   |
| <b>Input compatibility</b>           | DI1...DI8 discrete input level 1 PLC EN/IEC 61131-2<br>DI7, DI8 pulse input level 1 PLC IEC 65A-68<br>STOA, STOB discrete input level 1 PLC EN/IEC 61131-2<br><br>Positive logic (source) DI1...DI8), < 5 V, > 11 V<br>Negative logic (sink) DI1...DI8), > 16 V, < 10 V<br>Positive logic (source) DI7, DI8), < 0.6 V, > 2.5 V<br>Positive logic (source) STOA, STOB), < 5 V, > 11 V |
| <b>Sampling duration</b>             | 2 ms +/- 0.5 ms DI1...DI8) - discrete input<br>5 ms +/- 1 ms DI7, DI8) - pulse input<br>1 ms +/- 1 ms AI1, AI2, AI3) - analog input<br>5 ms +/- 1 ms AQ1, AQ2) - analog output   |
| <b>Accuracy</b>                      | +/- 0.6 % AI1, AI2, AI3 for a temperature variation 60 °C analog input<br>+/- 1 % AQ1, AQ2 for a temperature variation 60 °C analog output   |
| <b>Linearity error</b>               | AI1, AI2, AI3 +/- 0.15 % of maximum value analog input<br>AQ1, AQ2 +/- 0.2 % analog output   |
| <b>Refresh time</b>                  | Relay output R1, R2, R3)5 ms +/- 0.5 ms)   |
| <b>Isolation</b>                     | Between power and control terminals  |
| <b>Environment</b>                   |  |
| <b>Operating altitude</b>            | <= 3280.84 ft (1000 m) without derating<br>1000...4800 m with current derating 1 % per 100 m   |
| <b>Operating position</b>            | Vertical +/- 10 degree   |
| <b>Product Certifications</b>        | CSA<br>UL<br>TÜV   |
| <b>Marking</b>                       | CE   |
| <b>Standards</b>                     | UL 508C<br>EN/IEC 61800-3<br>EN/IEC 61800-5-1<br>IEC 61000-3-12<br>IEC 60721-3<br>IEC 61508<br>IEC 13849-1   |
| <b>Maximum THDI</b>                  | <48 % from 80...100 % of load IEC 61000-3-12   |
| <b>Assembly style</b>                | Enclosed   |
| <b>Electromagnetic compatibility</b> | Electrostatic discharge immunity test level 3 IEC 61000-4-2<br>Radiated radio-frequency electromagnetic field immunity test level 3 IEC 61000-4-3<br>Electrical fast transient/burst immunity test level 4 IEC 61000-4-4<br>1.2/50 µs - 8/20 µs surge immunity test level 3 IEC 61000-4-5<br>Conducted radio-frequency immunity test level 3 IEC 61000-4-6                           |

|   |  |
|---|--|
| <b>Environmental class (during operation)</b>                           | Class 3C3 according to IEC 60721-3-3<br>Class 3S3 according to IEC 60721-3-3                                     |
| <b>Maximum acceleration under shock impact (during operation)</b>       | 150 m/s <sup>2</sup> at 11 ms  |
| <b>Maximum acceleration under vibrational stress (during operation)</b> | 10 m/s <sup>2</sup> at 13...200 Hz   |
| <b>Maximum deflection under vibratory load (during operation)</b>       | 1.5 mm at 2...13 Hz  |
| <b>Permitted relative humidity (during operation)</b>                   | Class 3K5 according to EN 60721-3  |
| <b>Volume of cooling air</b>  | 77932.15 Gal/hr(US) (295 m <sup>3</sup> /h)  |
| <b>Overvoltage category</b>   | III  |
| <b>Regulation loop</b>  | Adjustable PID regulator   |
| <b>Insulation resistance</b>  | > 1 MOhm 500 V DC for 1 minute to earth  |
| <b>Noise level</b>  | 68.3 dB 86/188/EEC   |
| <b>Vibration resistance</b>   | 1.5 mm peak to peak 2...13 Hz)IEC 60068-2-6<br>1 gn 13...200 Hz)IEC 60068-2-6                                    |
| <b>Shock resistance</b>   | 15 gn 11 ms IEC 60068-2-27   |
| <b>Environmental characteristic</b>                                     | Chemical pollution resistance class 3C3 EN/IEC 60721-3-3<br>Dust pollution resistance class 3S3 EN/IEC 60721-3-3 |
| <b>Relative humidity</b>  | 5...95 % without condensation IEC 60068-2-3  |
| <b>Ambient air temperature for operation</b>                            | 5...122 °F (-15...50 °C) without derating)<br>122...140 °F (50...60 °C) with derating factor)                    |
|   | 68.3 dB  |
| <b>Pollution degree</b>   | 2  |
| <b>Ambient air transport temperature</b>                                | -40...158 °F (-40...70 °C)   |
| <b>Ambient Air Temperature for Storage</b>                              | -40...158 °F (-40...70 °C)   |

## Ordering and shipping details

|                          |                           |
|--------------------------|---------------------------|
| <b>Category</b>          | 22277-ATV930 FRAMES 3 & 4 |
| <b>Discount Schedule</b> | CP4E                      |
| <b>GTIN</b>              | 3606480883392             |
| <b>Returnability</b>     | Yes                       |
| <b>Country of origin</b> | IN                        |

## Packing Units

|                                     |                         |
|-------------------------------------|-------------------------|
| <b>Unit Type of Package 1</b>       | PCE                     |
| <b>Number of Units in Package 1</b> | 1                       |
| <b>Package 1 Height</b>             | 27.17 in (69.0 cm)      |
| <b>Package 1 Width</b>              | 18.11 in (46.0 cm)      |
| <b>Package 1 Length</b>             | 45.08 in (114.5 cm)     |
| <b>Package 1 Weight</b>             | 156.97 lb(US) (71.2 kg) |

## Offer Sustainability

|                                 |                       |
|---------------------------------|-----------------------|
| <b>Sustainable offer status</b> | Green Premium product |
|---------------------------------|-----------------------|

**California proposition 65**

WARNING: This product can expose you to chemicals known to the State of California to cause cancer and birth defects or other reproductive harm. For more information go to [www.P65Warnings.ca.gov](http://www.P65Warnings.ca.gov)

**REACH Regulation**

**EU RoHS Directive**

**Mercury free**

Yes

**China RoHS Regulation**

**RoHS exemption information**

**Environmental Disclosure**

**Circularity Profile**

**WEEE**

The product must be disposed on European Union markets following specific waste collection and never end up in rubbish bins.

**Upgradeability**

Upgraded components available

**Product data sheet**  
Dimensions Drawings

**Dimensions**

Front and Left View

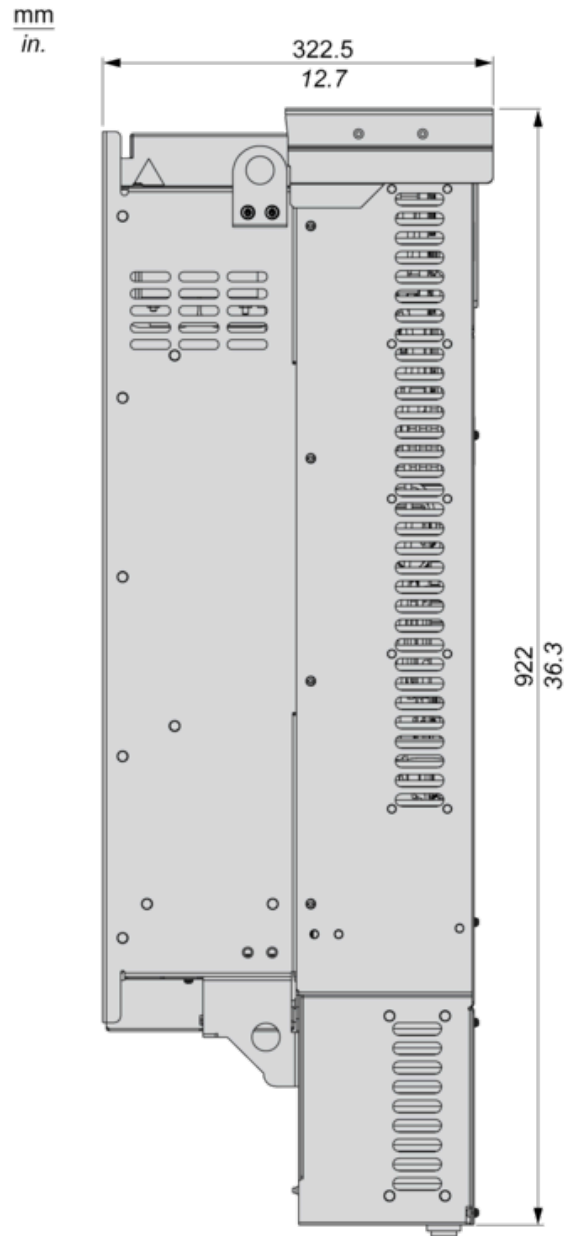
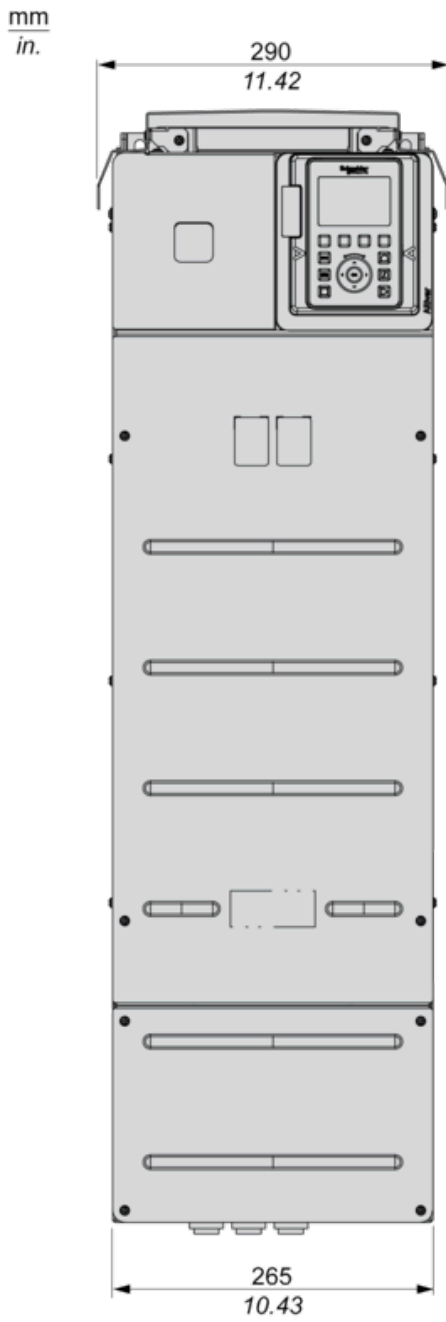

**Drives without IP21 Top Cover**

Rear view

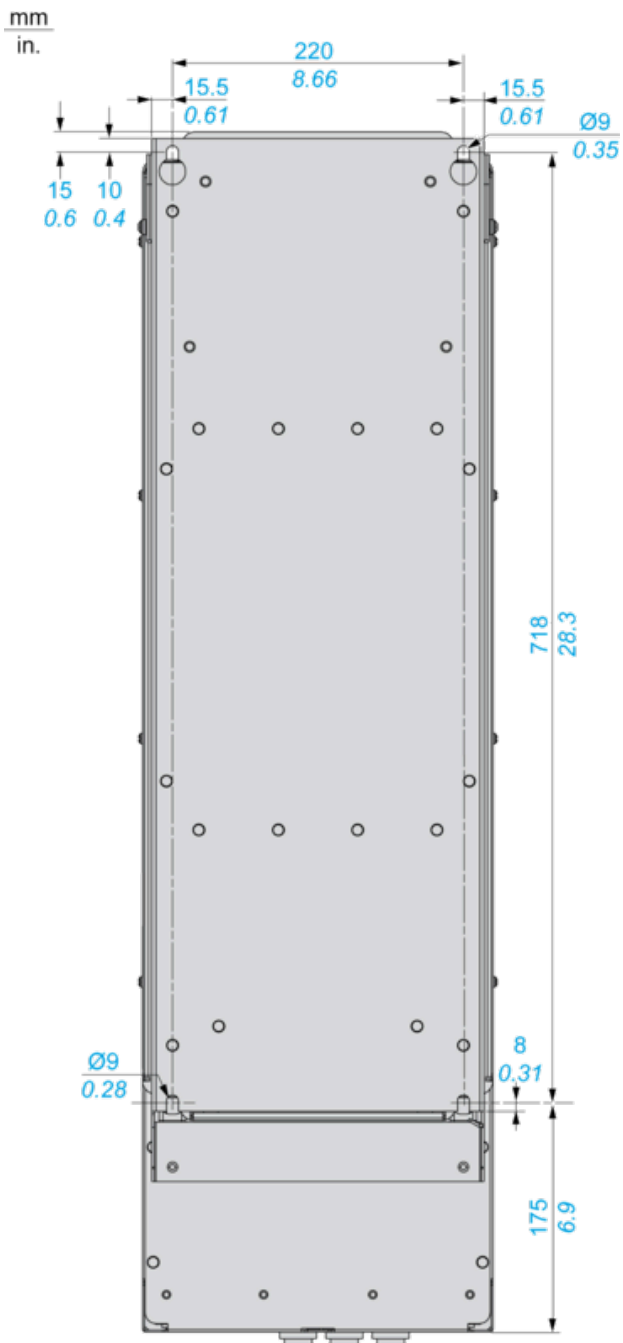

# Product data sheet

## Mounting and Clearance

# ATV930D55N4

### Clearances

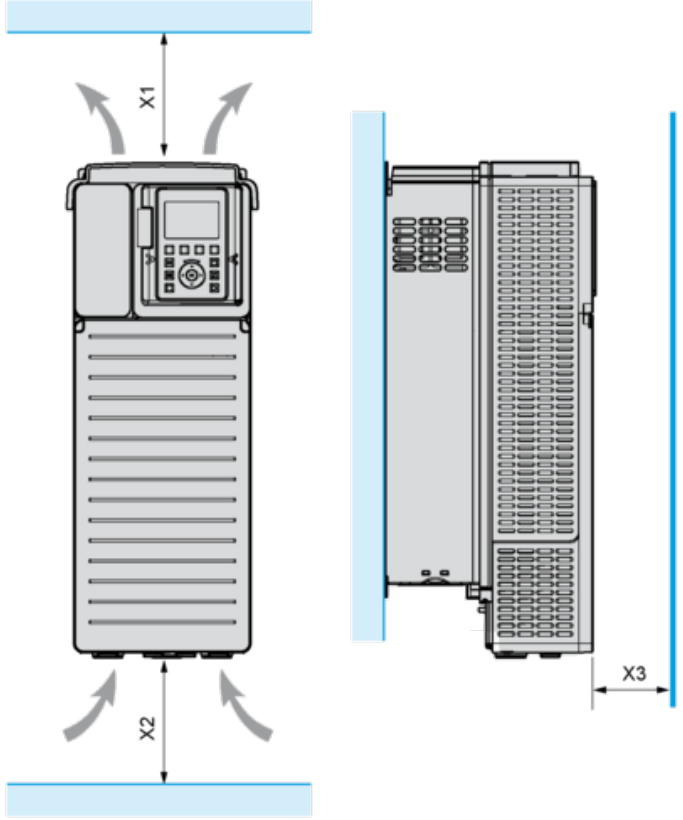

| X1                  | X2                  | X3                 |
|---------------------|---------------------|--------------------|
| ≥ 100 mm (3.94 in.) | ≥ 100 mm (3.94 in.) | ≥ 10 mm (0.39 in.) |

- Mount the device in a vertical position ( $\pm 10^\circ$ ). This is required for cooling the device.
- Do not mount the device close to heat sources.
- Leave sufficient free space so that the air required for cooling purposes can circulate from the bottom to the top of the drive.

# Product data sheet

## Mounting and Clearance

# ATV930D55N4

### Mounting Types

#### Mounting Type A: Individual IP21

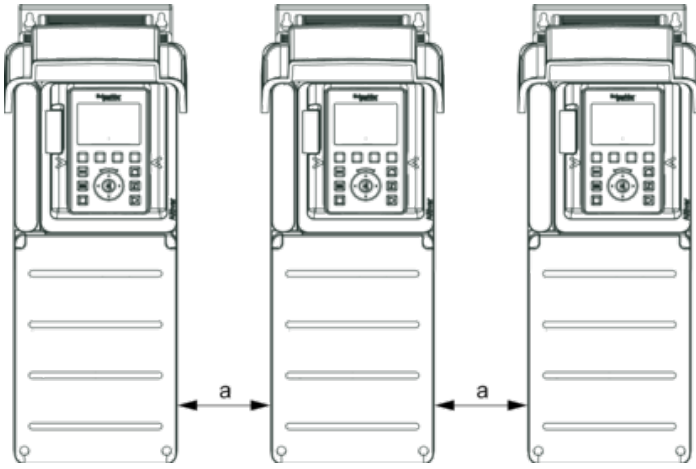

$a \geq 110 \text{ mm (4.33 in.)}$

#### Mounting Type B: Side by Side IP20 (Possible, 2 Drives Only)

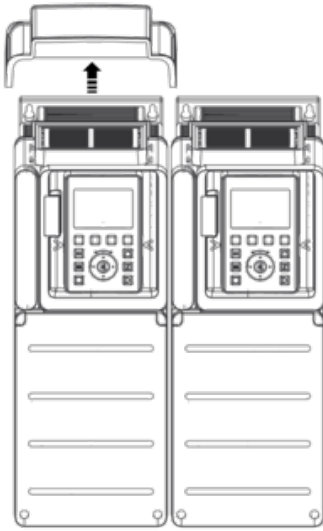

#### Mounting Type C: Individual IP20

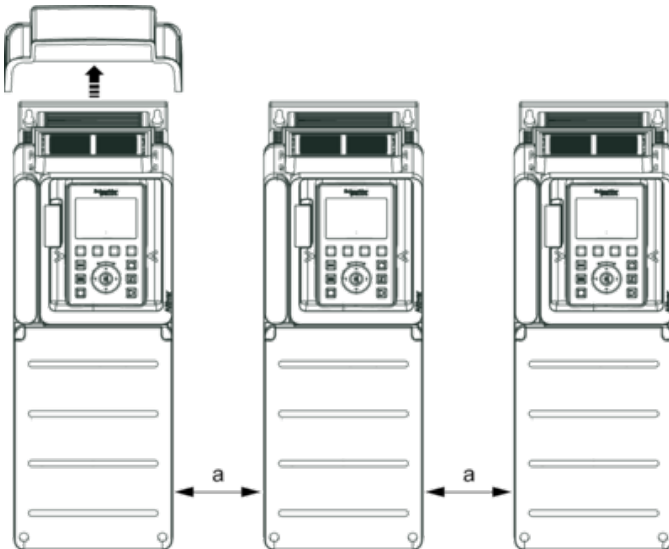

$a \geq 110 \text{ mm (4.33 in.)}$

# Product data sheet

## Connections and Schema

# ATV930D55N4

### Three-Phase Power Supply with Upstream Breaking via Line Contactor

Connection diagrams conforming to standards EN 954-1 category 1 and IEC/EN 61508 capacity SIL1, stopping category 0 in accordance with standard IEC/EN 60204-1

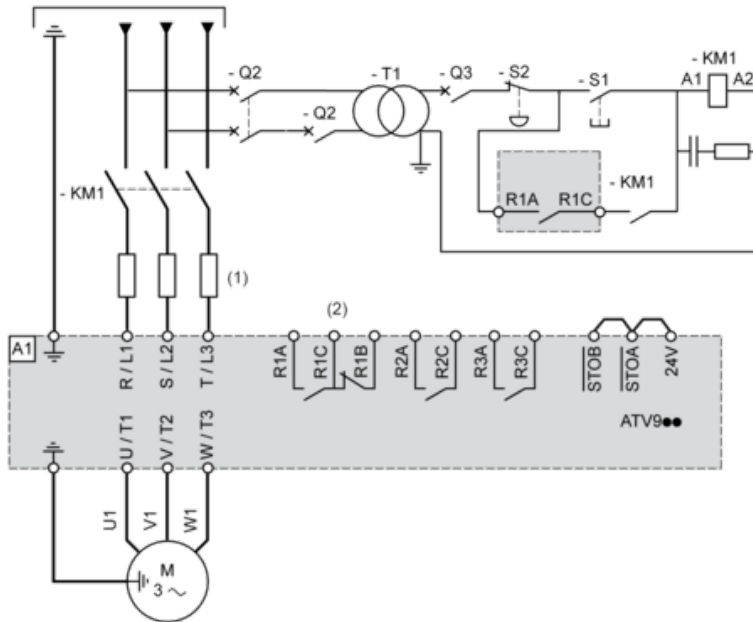

(1) Line choke if used

(2) Use relay R1 set to operating state Fault to switch Off the product once an error is detected.

A1 : Drive

KM1 : Line Contactor

Q2, Q3 : Circuit breakers

S1, S2 : Pushbuttons

T1 : Transformer for control part

# Product data sheet

## Connections and Schema

# ATV930D55N4

### Three-Phase Power Supply with Downstream Breaking via Contactor

Connection diagrams conforming to standards EN 954-1 category 1 and IEC/EN 61508 capacity SIL1, stopping category 0 in accordance with standard IEC/EN 60204-1

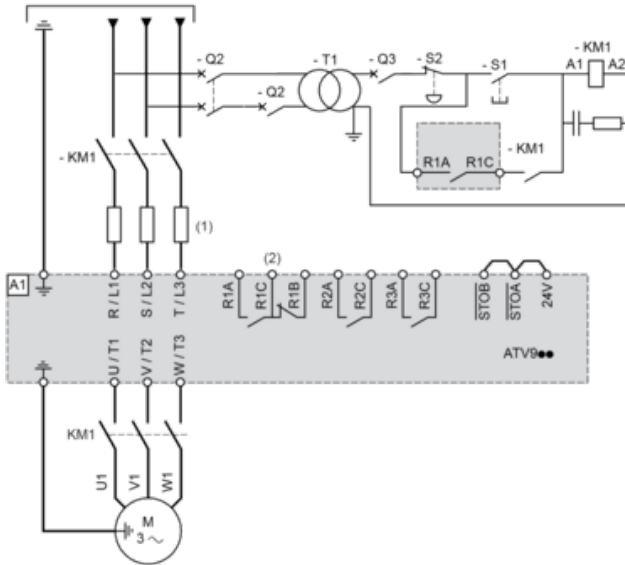

(1) Line choke if used

(2) Use relay R1 set to operating state Fault to switch Off the product once an error is detected.

A1 : Drive

KM1 : Contactor

# Product data sheet

## Connections and Schema

# ATV930D55N4

### Control Block Wiring Diagram

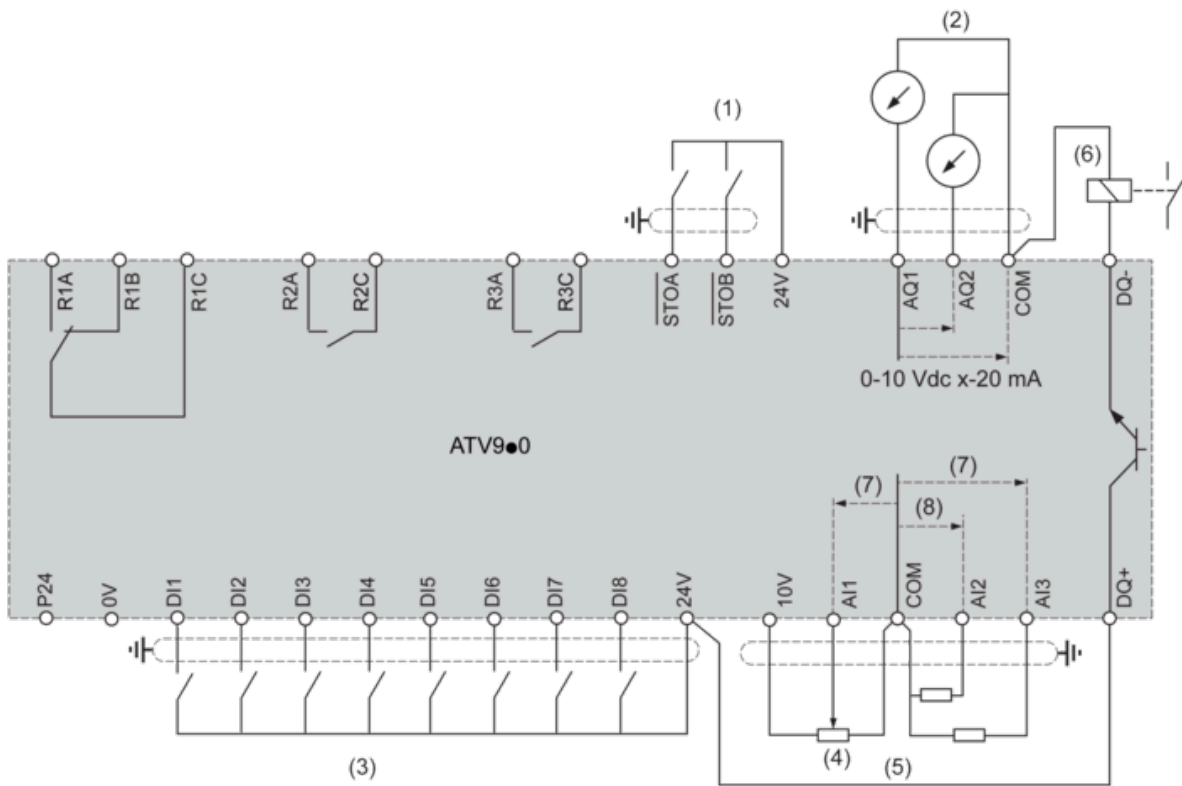

- (1) Safe Torque Off
  - (2) Analog Output
  - (3) Digital Input
  - (4) Reference potentiometer
  - (5) Analog Input
  - (6) Digital Output
  - (7) 0-10 Vdc, x-20 mA
  - (8) 0-10 Vdc, -10 Vdc...+10 Vdc
- R1A, R1B, R1C** : Fault relay  
**R2A, R2C** : Sequence relay  
**R3A, R3C** : Sequence relay

### Sensor Connection

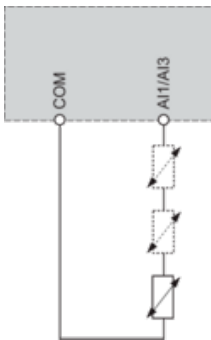

It is possible to connect either 1 or 3 sensors on terminals AI1 or AI3

# Product data sheet

## Connections and Schema

# ATV930D55N4

### Sink / Source Switch Configuration

The switch is used to adapt the operation of the logic inputs to the technology of the programmable controller outputs.

- Set the switch to Source (factory setting) if using PLC outputs with PNP transistors.
- Set the switch to Ext if using PLC outputs with NPN transistors.

#### Switch Set to SRC (Source) Position Using the Output Power Supply for the Digital Inputs

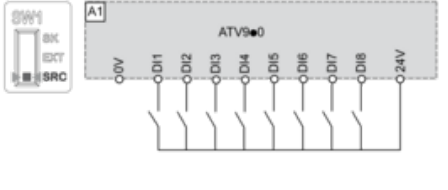

#### Switch Set to SRC (Source) Position and Use of an External Power Supply for the DIs

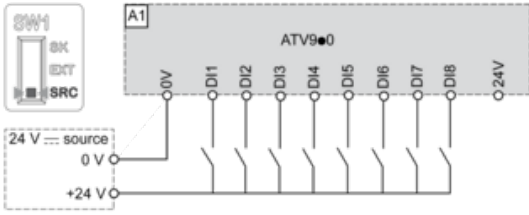

#### Switch Set to SK (Sink) Position Using the Output Power Supply for the Digital Inputs

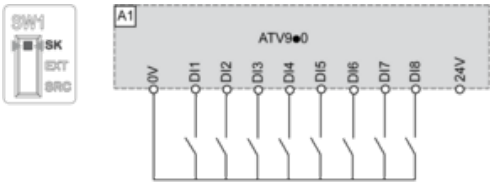

#### Switch Set to EXT Position Using an External Power Supply for the DIs

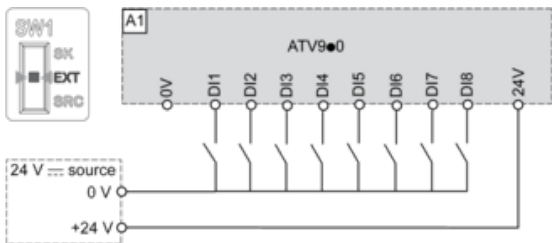

# Product data sheet

## Performance Curves

# ATV930D55N4

### Derating Curves

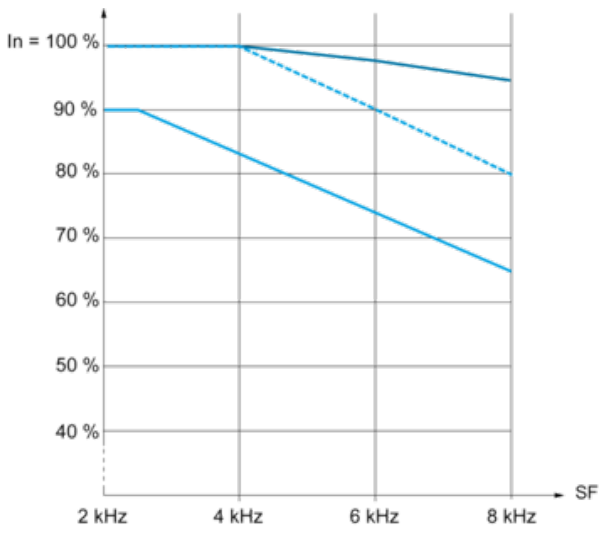

- 40 °C (104 °F) - Mounting type A, B and C
- ⋯ 50 °C (122 °F) - Mounting type A, B and C
- 60 °C (140 °F) - Mounting type B and C

In : Nominal Drive Current

SF : Switching Frequency

### Recommended replacement(s)